

MODEL 8651 SERIES LEVEL CONTROL SWITCH Setup and Operating Instructions

Mount the level control switch at a convenient location next to the feeder bowl, as near as possible (but not beneath) to where the parts will be dropped into the bowl. This position will assure even part distribution on the bottom of the bowl.

Set the switch bracket on the mounting post at such height that

the switch and its operating members will clear the feeder. For optimum operation, the paddle arm should be on a 45° angle from the horizontal, yet far enough away from the bowl wall to prevent the paddle from interfering with part movement. Optimum feeder performance is obtained when the bottom of the feeder bowl is

covered with parts; however, this will vary from one application to another.

Adjust the operating shaft by loosening the cap screw on the paddle adjuster and rotating the shaft to a position where the switch contacts will start and stop the hopper vibrator (or other parts supplying device). The screw can then be tightened

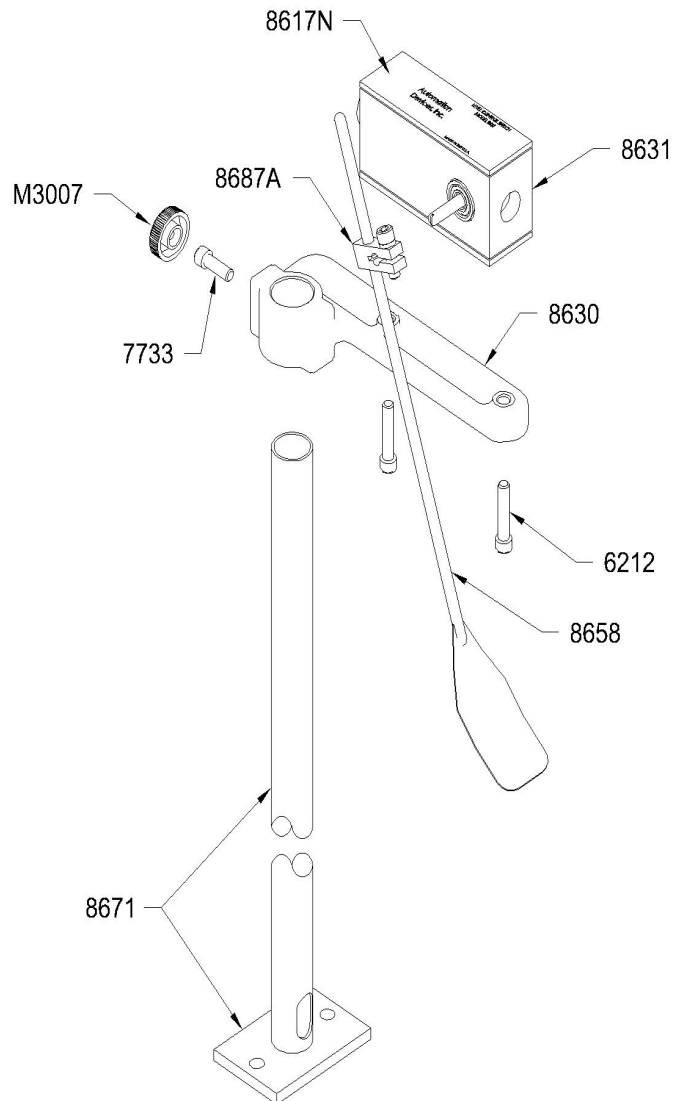
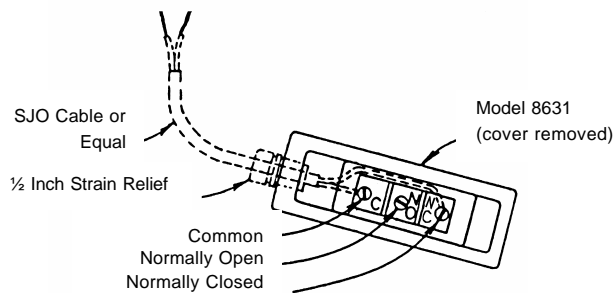

Parts List

Part Number	Quantity	Description
6212	2	1/4-20 x 1-1/4 SHCS
7733	1	1/4-20 x 3/4 SHCS
8630	1	Bracket
8658	1	Paddle Arm
8631	1	Switch Assembly
8617N	1	Nameplate
8671	1	Stand
8687A	1	Adjustor
M3007	1	Knob