



Amplitude Controller
Model 6800 Series

MODEL 6800.1D



GENERAL PURPOSE



Input: 120 VAC
50/60 HZ.

Output: 0-120 VAC
Double Unit Fuse Sizes:
Unit A 10 AMPS and
Unit B 5 AMPS

80% Duty Cycle at Rated AMPS

ADJUST AND SET UP FOR UNIT A

1. SELECTING OUTPUT PULSE MODE

Choose an output mode of 120 or 60 by sliding the OUTPUT PULSE switch to the appropriate position.

Other names for "120 Pulses Per Second" are AC or 7200 VPM (Vibrations Per Minute). "60" is the same as DC or 3600 VPM or Rectified.

Note: Readjust MAX pot after changing pulse mode setting.

2. INSTALLING THE PART SENSOR (Photo-sensor or Proximity Switch)

- A. Connect a three wire, current-sinking (NPN) or current-sourcing (PNP) sensor as shown on the enclosed wiring diagram. The sensor must be able to operate on 12VDC and be capable of switching at least 3.0 mA.
- B. Set switch (S2) for the proper logic. When the switch is in the "NORM" position, the control will run only when the sensor signal is present. The "NORM" position is used with Light-Operate Photoeyes (through beam). When switch (S2) is in the "INV" position, the control runs only when the sensor signal is not present. The "INV" switch position is used with Dark-Operate (reflective) Photoeyes and with Proximity Sensors.

Troubleshooting Tip: On new sensor installations if the sensor LED turns ON and OFF, but the control's output does not turn ON and OFF, turn the time delays all the way down, counter-clockwise. If this problem persists, the sensor may have an internal pull-up or pull-down resistor that is incompatible with the universal sensor input on the control. Dedicate the control's part sensor input to match the sensor's output type. Remove the resistor labeled "R4" and "NPN" when using a

NPN sensor. For a PNP sensor remove the resistor labeled "R3" and "PNP." The resistors are located near TB2-4. Use needle-nose pliers to twist and snap the resistor off. Removing the resistor does not void the warranty.

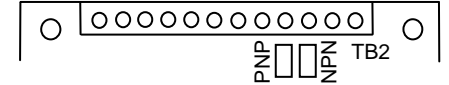

3. LIMITING THE MAXIMUM OUTPUT OF CONTROL

Adjust the MAX Output trimpot so that the output to the feeder reaches its desired maximum level when the MAIN CONTROL DIAL is turned fully clockwise. The MAX Output trimpot should be adjusted to keep the vibratory feeder from hammering when the control is turned up to full power.

NOTE: Output to feeder must be connected and the control set for proper output frequency (60 or 120 pulse) setting. The Run Jumper must be connected as shown on the wiring diagram.

- A. Power input should be OFF or disconnected.
- B. Rotate MAIN CONTROL DIAL on front cover to 0 or its minimum setting.
- C. Open cover to allow access to printed circuit card.
- D. Using CAUTION, turn power ON (no output should be present).
- E. Rotate the MAIN CONTROL DIAL on front cover slowly to its highest setting.
- F. Adjust the MAX output trimpot so that the output to the feeder reaches its desired maximum level when the MAIN CONTROL DIAL is turned fully clockwise. Turning the MAX output trimpot clockwise increases the maximum output level.

4. MAIN CONTROL DIAL

The output power is controlled by the **MAIN CONTROL DIAL**. A special logarithmic-tapered power-out curve (non-linear) spreads the power broadly across the **MAIN CONTROL DIAL** to help give maximum "Fine Control" over the output speed of the vibratory feeder. When very precise adjustment of the **MAIN CONTROL DIAL** is needed, increase the MIN trimpot setting and/or decrease the MAX trimpot setting. Use of an external analog signal in place of the control potentiometer is not recommended.

5. RUN JUMPER INPUT

The Run Jumper comes installed across TB2-7&8. The Run input may also be controlled by a relay contact, switch, or an NPN type of PLC output. Replace the factory-installed jumper with the "Run Signal" at terminals 7(-) and 8(+) of TB2 (small terminal strip). A contact must be able to switch 12VDC at 3.0 mA. The control will then run only when the contact is closed and the part sensor is calling for parts. The PLC's PNP output may be used if it is isolated from the internal power supply. To isolate it remove R24&25 located on the bottom side of the circuit board near TB2-5. Isolation for an NPN PLC output is optional.

6. SETTING THE TIME DELAYS

The sensor time delays can be set for independent OFF delay and ON delay periods. The time delay trim pots can be adjusted to provide the best individual response for the feeder (0 to 12 seconds).

By rotating the adjustment clockwise, the delay will become longer.

7. SETTING THE SOFT-START

The start-up of the control output can be adjusted to ramp up to the desired output level instead of starting abruptly. This keeps parts from falling off the tooling of a vibratory feeder when it turns on; it can reduce hammering during turn on; it can also simulate a paddle switch ON delay. Adjust the **SOFT** Start trimpot clockwise for the gentlest start (about a 10-second ramp up to full output). Turn the trimpot fully counter-clockwise for no soft start.

8. FEEDER BOWL/HOPPER INTERLOCK OUTPUT

The Feeder Bowl/Hopper Interlock feature (terminals 2 & 3 of TB2) can be connected to a 6000 Series control when control of a bulk material hopper is needed. The control interlock will prevent the hopper from operating anytime the bowl is turned OFF or in "STAND BY" mode. The Interlock output is 12 VDC (70 mA). The 12 VDC output is capable of switching 500 mA if an external power supply is used. Contact the factory for more details. The Interlock output can also be used to drive a solid state relay. The solid state relay is then used to operate any auxiliary equipment such as air valves. Two 6800 Series controls can also be interlocked, contact the factory for more details.

9. POWER SUPPLY

At the rated line voltage, the power supply is capable of providing a combined total current of 100 mA at 12 VDC. The total current includes the sensor and any auxiliary output accessories that are connected to the Bowl/Hopper Interlock terminals.

10. REMOTE SPEED CONTROL

Remote control of the power level can be accomplished by the following methods:

- A. 4-20mA signal from a PLC can be used to remotely vary the output of the control instead of the Main Control Dial. This feature is automatically turned ON whenever a 4-20mA signal is applied to the control (terminals 11 & 12 of TB2). The Main Control dial setting is ignored whenever there is a 4-20mA signal. The 4-20mA input is transformer isolated from the power line.
- B. 0-5VDC Analog input signal may be applied in place of the Main Control Dial. For further information contact the factory.

11. LINE VOLTAGE COMPENSATION

Fluctuations in the line Voltage can cause a feeder bowl to vary its feed rate. The line voltage compensation feature adjusts the control's output to help compensate for fluctuations in the supply voltage. If it becomes necessary to disable this

feature, cut through the circuit board trace labeled J8 using side cutter pliers or a knife.

12. SUPPLEMENTARY FEATURES

Special supplementary software features can be enabled on the 24-476/24-477 circuit boards. The features include: *Constant Feed Rate* regulation (CFR vibration feedback sensor required), *Constant On, High/Low Track* level control, *60 pulse polarity reversal, low pulse rate, power conservation mode, MIN. power trimpot, and two speed pots*. See the 6000 Series Advanced Application Note for details. The control comes from the factory configured with the "standard program". A different program may be in operation if any of the letters on the chip label are circled: "J8", "H", "POL", "CO" and "CFR".

WARNING:

Fuses should be replaced with Littelfuse 3AB "Fast Acting" type or equivalent of manufacturer's original value.

Mounting this control directly to a vibrating device will void the warranty.

DIMENSIONS

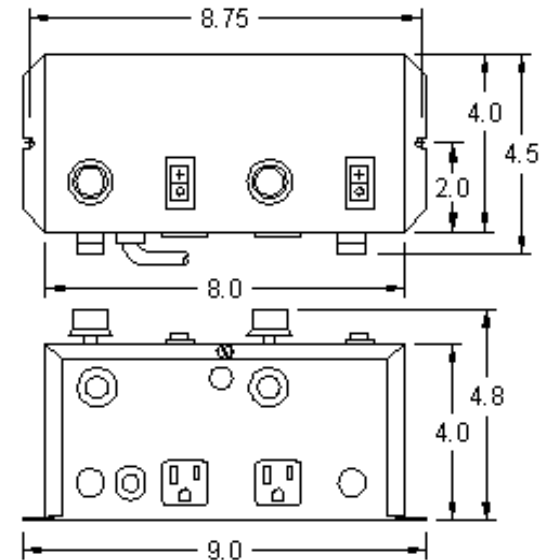

ADJUST AND SET UP FOR UNIT B

1. SELECTING OUTPUT PULSE MODE

Choose an output mode of 120 or 60 by sliding the OUTPUT PULSE switch to the appropriate position.

Other names for "120 Pulses Per Second" are AC or 7200 VPM (Vibrations Per Minute). "60" is the same as DC or 3600 VPM or Rectified.

Note: Readjust MAX pot after changing pulse mode setting.

2. LIMITING THE MAXIMUM OUTPUT OF CONTROL

Adjust the **MAX** Output trimpot so that the output to the feeder reaches its desired maximum level when the **MAIN CONTROL DIAL** is turned fully clockwise.

The **MAX** Output trimpot should be adjusted to keep the vibratory feeder from hammering when the control is turned up to full power.

NOTE: Output to feeder must be connected and the control set for proper output frequency (60 or 120 pulse) setting. The Run Jumper must be connected as shown on the wiring diagram.

- A. Power input should be **OFF** or disconnected.
- B. Rotate **MAIN CONTROL DIAL** on front cover to 0 or its minimum setting.
- C. Open cover to allow access to printed circuit card.
- D. Using **CAUTION**, turn power **ON** (no output should be present).
- E. Rotate the **MAIN CONTROL DIAL** on front cover slowly to its highest setting.
- F. Adjust the **MAX** output trimpot so that the output to the feeder reaches its desired maximum level when the **MAIN CONTROL DIAL** is turned fully clockwise. Turning the **MAX** output trimpot clockwise increases the maximum output level.

3. SETTING THE MINIMUM OUTPUT LEVEL OF CONTROL

When the vibratory feeder is nearly empty, turn the **MAIN CONTROL DIAL** fully counter-clockwise and adjust the **MIN** trimpot to just below the slowest speed that provides the proper feed rate.

4. REMOTE OFF/ON CONTROL

A Run Jumper has been installed at the factory as shown on the enclosed wiring diagram.

Note: TB2 terminals 5-7 are referenced to the line voltage circuit. Therefore any switch or contact connected to them must be isolated from other circuits.

Remote OFF/ON operation of the control can be configured to operate in one of the following ways.

- A. A low current switch such as a paddle switch can replace the factory-installed Run Jumper "J1." The "Run Contact" connects across terminals 6 and 7. The contact must be able to switch 5VDC and 2mA. The control will then run only when the contact is closed. Refer to Section A of the OFF/ON CONTROL GUIDE.
- B. Feeder Bowl/Hopper Interlock allows the Hopper control to operate only when the Bowl is running and the paddle switch contact is closed. The **interlock input** on terminals 11 and 12 of TB2 is controlled by the **interlock output** of a "Parts Sensing Feeder Bowl Control" such as a 6800 Series control.

Remove jumper "J1" of this control from terminals 6 and 7. Connect the Hopper Paddle switch to alternate terminals 5 and 6. Connect TB2 terminals 11 and 12 of this control to the "Parts Sensing Control". Refer to Section B of the OFF/ON CONTROL GUIDE. Check specific instructions for the "Parts Sensing Control" wiring.

Note: Two 6000 Series controls will not interlock to each other since neither one has an **interlock output**.

- C. Low Voltage DC can be used to turn the control **ON** and **OFF**. Move jumper "J1" from terminal 7, to terminal 5, (6 remains the same). Then connect the positive signal (+5 to 30VDC @ 10mA) to terminal 12 and the negative to terminal 11 of TB2. The control will now turn **ON** when the DC signal is present at terminals 11 and 12 of TB2. This input is optically isolated. Refer to Section C of the OFF/ON CONTROL GUIDE.
- D. AC Voltage may be used to turn the control **ON** and **OFF**. This requires a 105-250VAC signal, with 2mA maximum off-state leakage. Set up the control by moving the jumper "J1" from terminal 7, to terminal 5, (6 remains the same). Connect the 105-250VAC Signal to terminal 12 (L1) and the common (L2) to terminal 10 of TB2. The 6000 Series control will now turn **ON** whenever the AC signal is applied to terminals 10 and 12 of TB2. This input is optically isolated. Refer to Section D of the OFF/ON CONTROL GUIDE.

5. MAIN CONTROL DIAL

The output power is controlled by the **MAIN CONTROL DIAL**. A special logarithmic-tapered power-out curve (non-linear) spreads the power broadly across the **MAIN CONTROL DIAL** to help give maximum "Fine Control" over the output speed of the vibratory feeder. When very precise adjustment of the **MAIN CONTROL DIAL** is needed, increase the **MIN** trimpot setting and/or decrease the **MAX** trimpot setting. Use of an external analog signal in place of the control potentiometer is not recommended.

6. SETTING THE SOFT-START

The start-up of the control output can be adjusted to ramp up to the desired output level instead of starting abruptly. This keeps parts from falling off the tooling of a vibratory feeder when it turns on; it can reduce hammering during turn on; it can also simulate a paddle switch ON delay. Adjust the **SOFT** Start trimpot clockwise for the gentlest start (about a 10-second ramp up to full output). Turn the trimpot fully counter-clockwise for no soft start.

7. ADVANCED FEATURE PROGRAMS

Advanced features are available for specialized applications. These features can be enabled by the end user: 60 pulse waveform reversal; Main Control Dial follows a fixed curve; Control output turns off when the Main Control Dial is at 0; MIN pot disable, Power conservation mode; High speed/low speed/off operation; and Low pulse rates of 30, 20, 15, 10. For a full description of these features, please consult the factory.

TROUBLESHOOTING

Basic Procedure – To ascertain whether the problem lies in the controller, take the following steps:

- A. Check that the fuses are good. Disconnect the input power and tighten the screw terminals.
- B. Make sure that the proper input power is present.
- B. For the Unit A output to turn on, the **MAIN CONTROL DIAL** must be turned up and there must be a wire connected to TB2-7 & 8. It may also be necessary to bypass the sensor by changing the INV/NORM switch setting. It can be helpful to rotate the ON and OFF delay trimpots CCW. For this quick check, disconnect any 4-20mA control signal.
- C. For Unit B, the output should turn on anytime the **MAIN CONTROL DIAL** is turned up and a wire is connected from TB2-6 to TB2-7 on Unit B. If the wire is connected from TB2-5 to TB2-6 on Unit B, the output of Unit A must be ON in order for Unit B to turn ON.
- D. Connect an AC voltmeter across the LOAD terminals (with the LOAD connected) and vary the **MAIN CONTROL DIAL** from minimum to maximum. In 120 pulse mode, the output should vary from approximately 30% to 98% of the input voltage depending on the setting of the **MIN** and **MAX** trimpots. In 60 pulse mode the output should vary from 20% to around 85% of the input voltage.
- E. On new installations: If the Feeder only hums but it doesn't feed any parts, try changing the **60/120** switch to the opposite position.

When neither a humming sound nor any vibration can be detected in the vibratory feeder, the problem may be in the controller.

NOTE: The enclosure may feel quite warm when the load current is in the 12-15 Amp range.

In USA: Automation Devices, Inc.

7050 West Ridge Road

Fairview, PA 16415-2099

Phone: 814-474-5561

FAX: 814-474-2131 or 800-235-9382

Web Site: WWW.AUTODEV.COM

E-mail: SALES@AUTODEV.COM

OFF/ON CONTROL GUIDE

B) FEEDER BOWL/HOPPER INTERLOCK

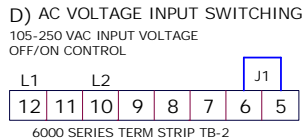
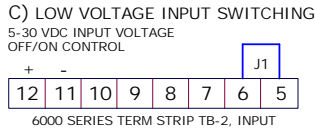
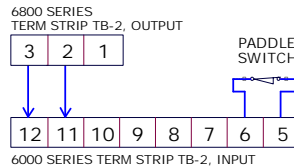
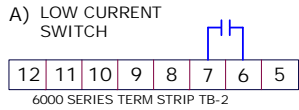

Amplitude Controller
Model 6800 Series

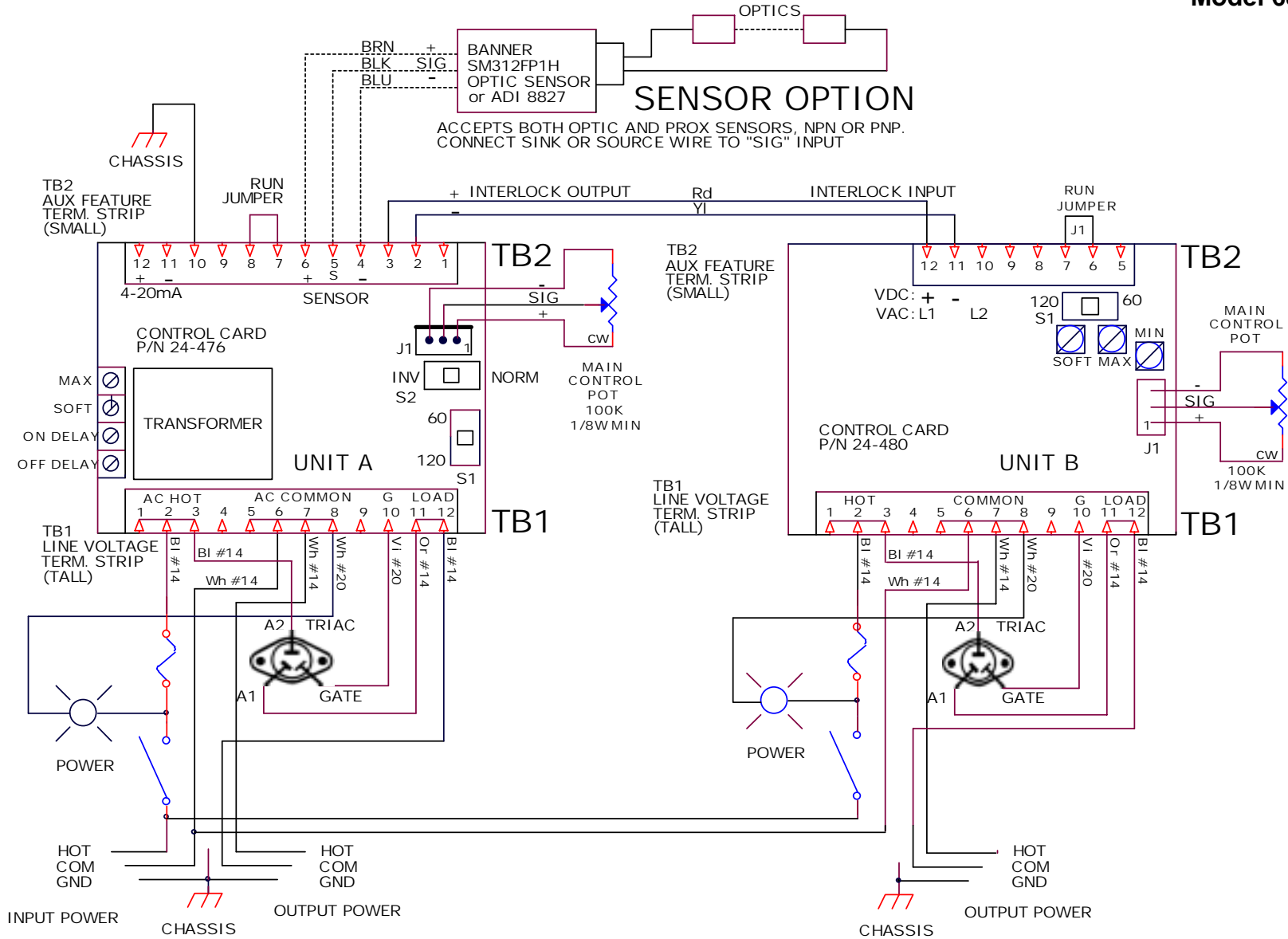

**MODEL
6800.1D**

**INPUT VAC
120 VAC**

**AMPS
10/5A**

**OUTPUT
0-120**



Good wiring practices for avoiding electrical noise problems.

Automation Devices controls have been designed with a high degree of immunity to electrical noise; however, depending on the control installation, electrical noise can cause problems. These problems occur in less than 1% of the product installations. Most electrical noise problems can be avoided by following some simple guidelines. Good wiring practices need to be used to prevent electrical noise from interfering with your control's operation. Another name for electrical noise is Electro-Magnetic Interference (EMI).

Symptoms of Electrical Noise

The symptoms of electrical noise would appear as follows: a brief pause or a brief "bump" in the vibratory feeder's output that the control automatically recovers from. In rare cases the control will either stop operating or run continuously at full power in 120 pulse (AC) mode until the power switch is slowly cycled OFF and ON.

Sources of Electrical Noise

Electrical noise is generated by devices like relay coils, solenoid valves, contactors, servo motors, and (variable frequency inverter) motor drives. The electrical noise is then transferred to another device by one of three ways. The noise could be conducted through the power wires, or capacitively coupled from

wire to adjacent wire, or it is transmitted from the wires of a noise source.

Solutions for Electrical Noise

1. Use shielded wires for all I/O (Input / Output) signals. The I/O signals may include: Paddle switch, Run input, Interlock input. The shield "drain" wire should be tied to the chassis in the control. The drain wire should be kept shorter than 2". Please see the picture below.

Example of a "drain" wire termination

2. Never run I/O signal wires in the same conduit or raceway as AC power lines such as wires to motors, solenoids, heaters, welders and vibratory feeder controls, etc.

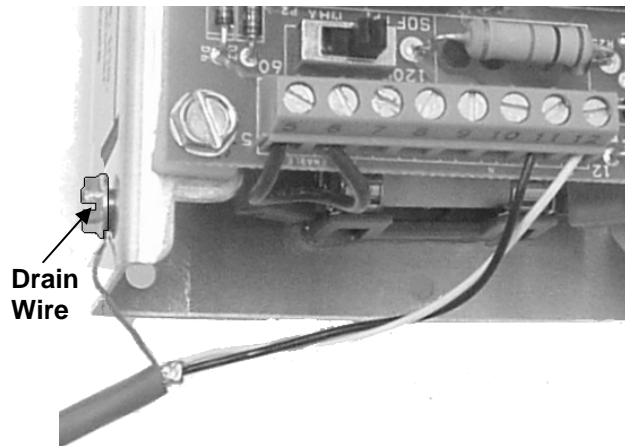

3. I/O wires within an enclosure should be routed as far away as possible from relays, solenoids, transformers, power wiring and other noisy equipment. Keep the I/O signal wires separate from the control's input and output power wiring. Secure the wires in place.

4. Whenever relays or solenoid valves are used, install a Snubber on them to reduce electrical noise. Use a diode on a DC coil. Use a RC Snubber on an AC coil.

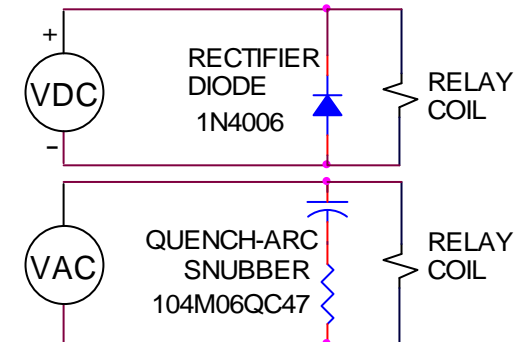

5. In extremely high EMI environments, Power Line Filters and ferrite beads can be effective. Install ferrite beads on I/O signal wires as close as possible to the circuit board terminal strip. Loop the wire through the bead several times or use several beads on each wire for additional protection.

In USA: Automation Devices, Inc.

7050 West Ridge Road
Fairview, PA 16415-2099

Phone: 814-474-5561

FAX: 814-474-2131 or 800-235-9382

Web Site: WWW.AUTODEV.COM

E-mail: SALES@AUTODEV.COM