



**Amplitude Controller  
Model 6045.2 Series  
OPEN FRAME**



**MODEL 6045.2**

**SUB PANEL MOUNT**

**Input: 240 VAC  
50/60 HZ.**

**Output: 0-240 VAC  
Single Unit Fuse Size: 8 AMPS  
80% Duty Cycle at Rated AMPS**

**Note: Mount Open Frame controls within an enclosure.**

## **ADJUSTMENTS AND SET UP**

### **1. SELECTING OUTPUT PULSE MODE**

Choose an output mode of 120 or 60 by sliding the OUTPUT PULSE switch to the appropriate position.

Other names for "120 Pulses Per Second" are AC or 7200 VPM (Vibrations Per Minute). "60" is the same as DC or 3600 VPM or Rectified.

**Note: Readjust MAX pot after changing pulse mode setting.**

### **2. LIMITING THE MAXIMUM OUTPUT OF CONTROL**

Adjust the **MAX** Output trimpot so that the output to the feeder reaches its desired maximum level when the **MAIN CONTROL DIAL** is turned fully clockwise. The **MAX** Output trimpot should be adjusted to keep the vibratory feeder from hammering when the control is turned up to full power.

**NOTE: Output to feeder must be connected and the control set for proper output frequency (60 or 120 pulse) setting. The Run Jumper must be connected as shown on the wiring diagram.**

- Power input should be **OFF** or disconnected.
- Rotate **MAIN CONTROL DIAL** on front cover to 0 or its minimum setting.
- Open cover to allow access to printed circuit card.
- Using **CAUTION**, turn power **ON** (no output should be present).
- Rotate the **MAIN CONTROL DIAL** on front cover slowly to its highest setting.

- Adjust the **MAX** output trimpot so that the output to the feeder reaches its desired maximum level when the **MAIN CONTROL DIAL** is turned fully clockwise. Turning the **MAX** output trimpot clockwise increases the maximum output level.

### **3. REMOTE OFF/ON CONTROL**

A Run Jumper has been installed at the factory as shown on the enclosed wiring diagram.

Note: TB2 terminals 5-7 are referenced to the line voltage circuit. Therefore any switch or contact connected to them must be isolated from other circuits.

Remote OFF/ON operation of the control can be configured to operate in one of the following ways.

- A low current switch such as a paddle switch can replace the factory-installed Run Jumper "J1." The "Run Contact" connects across terminals 6 and 7. The contact must be able to switch 5VDC and 2mA. The control will then run only when the contact is closed. Refer to Section A of the OFF/ON CONTROL GUIDE.
- Feeder Bowl/Hopper Interlock allows the Hopper control to operate only when the Bowl is running and the paddle switch contact is closed. The **interlock input** on terminals 11 and 12 of TB2 is controlled by the **interlock output** of a "Parts Sensing Feeder Bowl Control" such as a 6800 Series control.

Remove jumper "J1" of this control from terminals 6 and 7. Connect the Hopper Paddle switch to alternate terminals 5 and 6. Connect TB2 terminals 11 and 12 of this control to the "Parts Sensing Control". Refer to Section B of the OFF/ON CONTROL GUIDE. Check specific instructions for the "Parts Sensing Control" wiring.

Note: Two 6040 Series controls will not interlock to each other since neither one has an **interlock output**.

C. Low Voltage DC can be used to turn the control **ON** and **OFF**. Move jumper "J1" from terminal 7, to terminal 5, (6 remains the same). Then connect the positive signal (+5 to 30VDC @ 10mA) to terminal 12 and the negative to terminal 11 of TB2. The control will now turn **ON** when the DC signal is present at terminals 11 and 12 of TB2. This input is optically isolated. Refer to Section C of the OFF/ON CONTROL GUIDE.

D. AC Voltage may be used to turn the control **ON** and **OFF**. This requires a 105-250VAC signal, with 2mA maximum off-state leakage. Set up the control by moving the jumper "J1" from terminal 7, to terminal 5, (6 remains the same). Connect the 105-250VAC Signal to terminal 12 (L1) and the common (L2) to terminal 10 of TB2. The 6000 Series control will now turn **ON** whenever the AC signal is applied to terminals 10 and 12 of TB2. This input is optically isolated. Refer to Section D of the OFF/ON CONTROL GUIDE.

TB-2 terminals 5-7 are transformer isolated from the line voltage circuit.

#### 4. MAIN CONTROL DIAL

The output power is controlled by the **MAIN CONTROL DIAL**. A special logarithmic-tapered power-out curve (non-linear) spreads the power broadly across the **MAIN CONTROL DIAL** to help give maximum "Fine Control" over the output speed of the vibratory feeder.

#### 5. SETTING THE SOFT-START

The start-up of the control output can be adjusted to ramp up to the desired output level instead of starting abruptly. This keeps parts from falling off the tooling of a vibratory feeder when it turns on; it can reduce hammering during turn on; it can also simulate a paddle switch ON delay. Adjust the **SOFT** Start trimpot clockwise for the gentlest start (about a 10-second ramp up to full output). Turn the trimpot fully counter-clockwise for no soft start.

#### 6. LINE VOLTAGE COMPENSATION

Fluctuations in the line Voltage can cause a feeder bowl to vary its feed rate. The line voltage

compensation feature adjusts the control's output to help compensate for fluctuations in the supply voltage. If it becomes necessary to disable this feature, remove resistor R4 from the bottom of the board with a pair of pliers, twist R4 to snap it off.

### 7. REMOTE SPEED CONTROL

Remote control of the power signal level can be accomplished by the following methods:

- 0-5VDC Analog input signal may be applied in place of the Main Control Dial. For further information, contact the manufacturer.
- 4-20mA signal from a PLC can be used to remotely vary the output of the control instead of the Main Control Dial. This feature is automatically turned on whenever a 4-20mA signal is applied to the control. To return control to the Main Control Dial, remove the 420mA signal by turning it off or use a switch to open the circuit. The 4-20mA input is transformer isolated from the power line.
- Remote control of the output power level can be accomplished by using an optional **Step Up/Down Remote Speed Interface**.

#### WARNING:

**Fuses should be replaced with Littelfuse 3AB "Fast Acting" type or equivalent of manufacturer's original value.**

**Mounting this control directly to a vibrating device will void the warranty.**

#### TROUBLESHOOTING

Basic Procedure – To ascertain whether the problem lies in the controller, take the following steps:

- Check for good fuses. Disconnect the input power and tighten the screw terminals.
- Make sure that the proper input power is present and the RUN jumper is connected. The output should turn on anytime the **MAIN CONTROL DIAL** is turned up and a wire is connected from TB2-6 to TB2-7. (This assumes that the 4-20mA input isn't in use).

If the wire is connected from TB2-5 to TB2-6, an auxiliary voltage input has to be present before the control will operate, see the section titled "**Remote OFF/ON control**" for more information.

- Connect an AC voltmeter across the LOAD terminals (with the LOAD connected) and vary the **MAIN CONTROL DIAL** from minimum to maximum. In 120 pulse mode, the output should vary from approximately 30% to 98% of the input voltage depending on the setting of the **MIN** and **MAX** trimpots. In 60 pulse mode the output should vary from 20% to around 85% of the input voltage.
- On new installations: If the Feeder only hums but it doesn't feed any parts, try changing the **60/120** switch to the opposite position.

When neither a humming sound nor any vibration can be detected in the vibratory feeder, the problem may be in the controller.

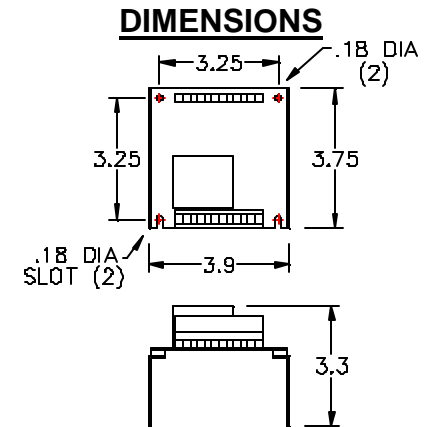

#### Automation Devices, Inc.

7050 West Ridge Road  
Fairview, PA 16415-2099  
Phone: 814-474-5561

FAX: 814-474-2131 or 800-235-9382

Web Site: [WWW.AUTODEV.COM](http://WWW.AUTODEV.COM)

E-mail: [SALES@AUTODEV.COM](mailto:SALES@AUTODEV.COM)

# Automation Devices, Inc.

## Automation Devices, Inc.

7050 West Ridge Road  
 Fairview, PA 16415-2099  
 Phone: 814-474-5561  
 FAX: 814-474-2131 or 800-235-9382  
 Web Site: [WWW.AUTODEV.COM](http://WWW.AUTODEV.COM)  
 E-mail: [SALES@AUTODEV.COM](mailto:SALES@AUTODEV.COM)

### MODEL 6045.2 OPEN FRAME MODEL IMPORTANT: APPLICATION NOTE

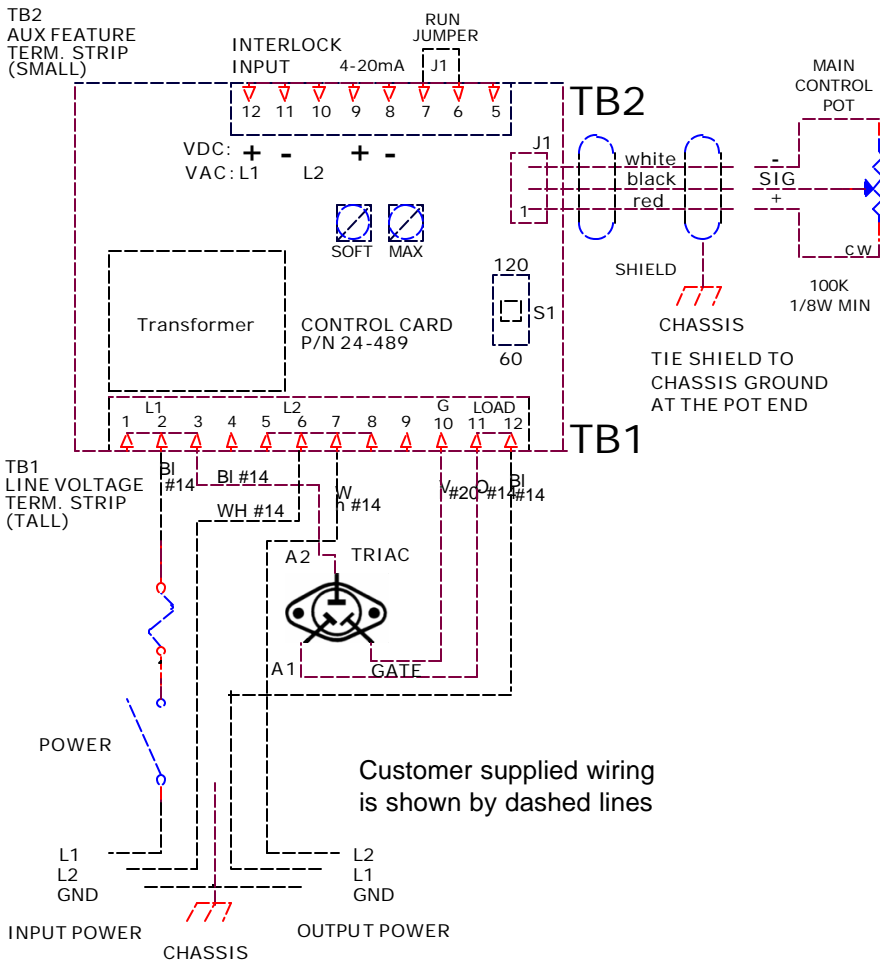

## OFF/ON CONTROL GUIDE

See section 4 of the Application Note for more details.

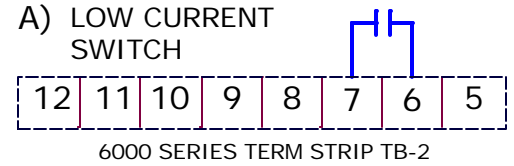

## B) FEEDER BOWL/HOPPER INTERLOCK

6800 SERIES  
 TERM STRIP TB-2, OUTPUT

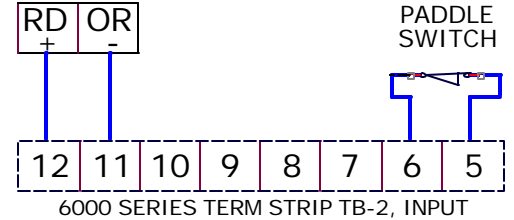

## C) LOW VOLTAGE INPUT SWITCHING (DC Voltage from PLC)

5-30 VDC INPUT VOLTAGE  
 OFF/ON CONTROL

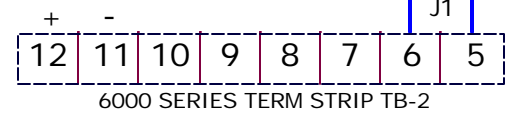

## D) AC VOLTAGE INPUT SWITCHING

105-250 VAC INPUT VOLTAGE  
 OFF/ON CONTROL

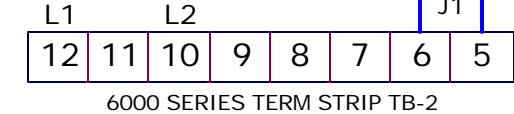

## TRIAC REFERENCE GUIDE

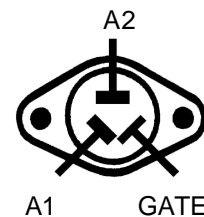

**MODEL 6045.2**      **INPUT VAC 240VAC**      **AMPS 8A**      **OUTPUT 0-240**