

Automation Devices, Inc.

Model 9300 Vibrator INSTALLATION & OPERATING INSTRUCTIONS

➤ DESCRIPTION

The Model 9300 vibrator is an electromagnetic vibrator. Its 9 ½ pound weight makes the Model 9300 vibrator ideally suited for use on medium size hoppers, chutes, tracks or bins. The coil is encapsulated to protect against liquids, metallic dust, and mechanical damage. Power consumption is approximately 225 Watts.

➤ OPERATION

The Model 9300 is designed to operate from a **half-wave rectified** Power source. The Automation Devices' Model 6000 Series controller can be used to control the amplitude. *The controller must be set to DC operation.* The Model 9300 vibrator will produce 3600 vibrations per minute when connected to a 60 Hz power source. Units can be ordered for 50 Hz operation.

➤ INSTALLATION

When assembled to an Automation Devices' side delivery hopper, the Model 9300 vibrator is attached to the underside of the sloping hopper bottom. The vibrator has been adjusted at the factory to deliver optimum vibration for that size hopper.

If the vibrator is to be mounted on your own equipment, then care should be exercised in selecting the mounting location. Generally speaking, the vibrator should be mounted on a bin or hopper where the surface is not reinforced by braces or supports and is free to flex. Centerline mounting is suggested at a point 1/4 to 1/3 of the distance up from the hopper discharge and if possible on a sloping surface.

The Model 9300 vibrator may be mounted in any position. On thin wall bins and hoppers, a mounting plate (smaller than the vibrator base) should be welded to the bin wall. The vibrator must be securely fastened and lock washered so that no movement occurs between the vibrator and the mounting surface.

The Model 9300 vibrator is constructed using heat resistant components where needed and internal temperatures up to 185°F (85°C) are permissible. The ambient temperature should not exceed 100°F.

Note: AN ELECTRICAL GROUND CONNECTION SHOULD ALWAYS BE INSTALLED.

All dimensions below are in inches.

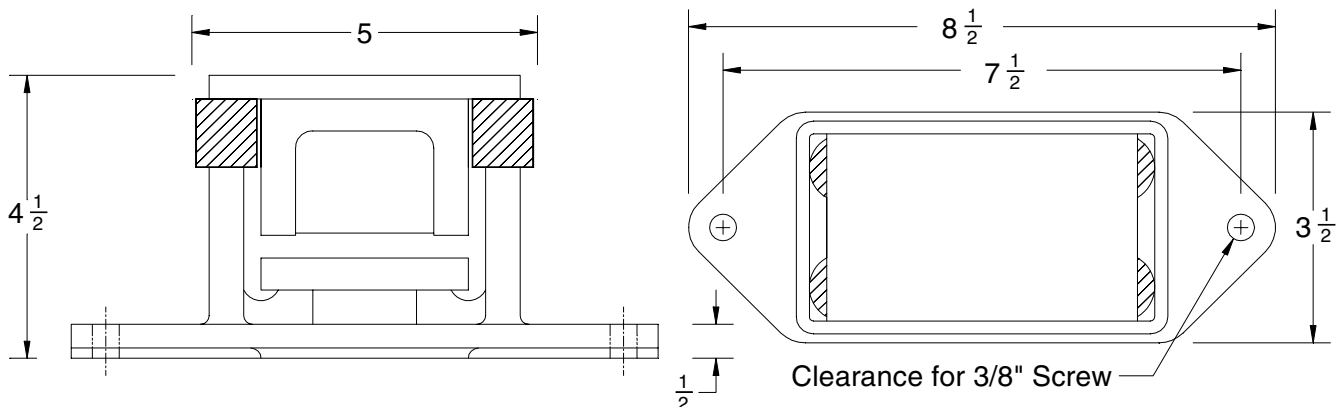

IJ02.01

Automation Devices, Inc.

7050 West Ridge Road
Fairview, PA 16415-2099

Phone: 814-474-5561

FAX: 814-474-2131 or 800-235-9382

Web Site: www.autodev.com E-mail: info@autodev.com