



Amplitude Controller Model 6450 Series



Model 6451.3 pictured

Models 6450.3*, 6451.3, 6452.3*, 6453.3,
* includes vibration sensor P/N 6476.3



File No. E183233

Input Voltage: 85 - 264 VAC, 50/60 HZ.

Output Voltage: 0 -120/240 VAC

Max. output voltage matches input voltage

Output Frequency: 5-300Hz

Input Fuse Size: 5 AMPS

Rated Output Current:

6450.3, 6451.3: 3 Amps at 120V or 1.5 A at 240V

6452.3, 6453.3: 9 Amps at 120V or 4.5 A at 240V

ADJUSTMENT AND SET UP

MOUNTING

The controls may be mounted vertically or horizontally, but the controls stay cooler when mounted vertically. Mount the control to a metal plate or mount it so that the back of the heat sink is fully exposed to the air.

ELECTRICAL CONNECTIONS

Make the electrical connections prior to turning the control on. Once connections are made, any desired changes to the software settings can be made with the cover closed. **Warning: Shock Hazard! Do not operate control with the cover open.**

Safety codes require single phase 120 or 240 VAC installations to bypass fuse L2. To bypass, remove the wire connecting TB1-L2 to the L2 fuse holder. Remove the terminal end of the wire connecting the L2 fuse to the power switch and connect it to TB1-L2.

1. PART SENSOR INPUT

(Photo-sensor or Proximity Switch)

Connect a three wire, current-sinking (NPN) or current-sourcing (PNP) sensor to TB2 as shown on the enclosed wiring diagram. The sensor must be able to operate on 12VDC and be capable of switching at least 3.0 mA. See Parts Sensor Settings section for more operation information.

2. RUN JUMPER INPUT

A Run Jumper comes installed from the factory as shown on the enclosed wiring diagram.

If the run jumper input is to be controlled by a relay contact, switch, or other device, replace the factory-installed jumper (see TB2 of the wiring diagram) with the contact device. The contact must be able to switch 12VDC at 3.0 mA. The control will then run only when the contact is closed and the part sensor is calling for parts. The right column of the display shows the run status with "R= 1" or "R= 0."

If the run input will be controlled by a current sourcing PLC output, use the "Sig" and "-" terminals (see TB2 on the wiring diagram).

For the High/Low parts sensing mode, a second parts sensor (PNP type only) connects to the run input in place of the run jumper.

3. AUXILLERY OUTPUT

The right column of the display shows the status of the Aux output, "A=1" or "A=0." The Feeder Bowl/Hopper Interlock "+" and "sig" (see TB2 on the wiring diagram) can be connected to an ADI 6000 Series control (TB2-11 & 12) when control of a bulk material hopper is needed. The control interlock will prevent the hopper from operating anytime the bowl is turned "OFF" or in "STAND BY" mode. The Interlock output is capable of switching 12 VDC at 85 mA. The Interlock output can also be used to drive a solid state relay that can operate auxiliary equipment such as air valves. See Figure 2 on the wiring diagram. One VF series control can be interlocked to another. The aux output of the master control connects to the run input of the subordinate.

A 1 Watt or 0.6 Watt 12VDC air solenoid or a relay can be driven by the Aux output. Note: a diode (1N4006) must be placed across the solenoid in the reverse polarity to adsorb the energy when the solenoid is de-energized. The "bar" side of the diode connects to TB2 "+" and the "solid colored" side connects to TB2 "SIG." Failure to use a diode in reverse polarity voids the warranty.

4. INTERNAL POWER SUPPLY

At the rated line voltage, the line isolated power supply is capable of providing a combined total current of 150 mA at 12 VDC. The total current includes the parts sensor, auxiliary output accessories, and CFR sensor.

5. POWER CONNECTIONS

The control can operate on a power line from 85 to 264VAC. The plug can be connected to a standard North American outlet. Cut the plug end(s) off for 208 and 240VAC and make proper plug-in connections for the factory's power lines.

The variable frequency control is so efficient that it recaptures the energy from the feeder coils every time they turn off. Because of this the output power cord may be larger than the input cord. Model 6472.3 uses a #12 AWG output cord and the receptacle is not provided. Model 6474.3 uses a #10 AWG output cord and the receptacle is not provided.

6. EXTERNAL SPEED CONTROL CONNECTIONS

The following methods of remote power level control can be utilized when desired:

- A. CFR sensor can maintain a constant feed rate. Attach the CFR sensor to terminals ACCEL “-“ (blue) and to ACCEL “+” (brown). (Then update the software settings. Sections 11-A and 13-B)
- B. 4-20mA signal can be connected by bringing the positive signal wire to 4-20 “+” and ground to 4-20 “-“. (Update software settings. Sect 11-B)
- C. 0-10VDC Analog input signal can be connected by bringing the positive signal wire to 0-10V “+” and ground to 0-10 “-“. (Update the software settings. Section 11-C)

SOFTWARE ADJUSTMENTS

Once the electrical connections have been made, the control can be turned on. The software settings can be adjusted as desired through the control menu.

DISPLAY MESSAGES

The normal operating display shows the status of the control with regard to input signals and control settings. See the Control Menu Layout page for display message details.

NAVIGATING THE CONTROL MENU

The control uses four programming keys to program the control. The “**I/O**” key controls run, stop, and over-ride.

- A. The **ENTER** key allows entry to the menu and access to adjust each setting. Push and hold the enter key to enter the program mode. If the security feature has been enabled, enter the proper code. Once inside the menu, the enter key selects a menu item or a parameter to adjust. Any changes to the settings are saved at power-down.
- B. The **BACK** key moves the current menu location up one level higher than it was before. It is also used to get back to the normal operating display.
- C. The **Arrow Down** key allows the user to step down through the program menu or to decrease a setting.
- D. The **Arrow Up** key allows the user to step up through the program menu or to increase a setting.
- E. The “**I/O**” key allows the user to temporarily stop or to start the control’s operation. When the LCD status reads “Stop/Run,” hold the “I/O” key down for just over a second, and the control will start the over-ride operation. In over-ride mode the output turns on regardless of I/O connections and status.

See the “Control Menu Layout” chart for the menu structure. When in the menu mode and no keys are

pressed for 1 minute, the display reverts to the normal operating display mode.

7. AMPLITUDE POWER SETTING

The output power is controlled by the up and down arrow keys. The power setting can be adjusted with the keys unless the security feature lock has been selected. Once the proper security code has been entered, the power setting may be adjusted under the “Power” menu. Note: the power setting may not be above the maximum power setting or below the minimum power setting level. The amplitude power setting is displayed in the following manner: “A= 50.0%.”

8. LIMITING THE MAXIMUM OUTPUT OF CONTROL

The “Max Amplitude” setting can be adjusted to keep a vibratory feeder from hammering or vibrating excessively when the control is turned up to full power. The maximum power setting can be found under the “Power” menu. It can be adjusted from 100.0% down to 40.0%.

Caution: it is recommended when using the CFR feature, that the Max output level of the control should be limited to prevent feeder coil from overheating. The amplitude could continue to increase if the system cannot get back to the desired vibration level.

9. SETTING THE MINIMUM OUTPUT OF CONTROL

The “Min Amplitude” setting can be adjusted to the desired low level of vibration. The minimum power setting can be found under the “Power” menu. It can be adjusted up from 0.0% to 95.0%. Note: the software does not allow the minimum level to be within 5.0 counts of the maximum level.

10. SETTING THE SOFT-START

The start-up of the control’s output can be adjusted to ramp up to the desired output level instead of starting abruptly. Soft-start keeps parts from falling off the tooling, reduces spring shock, and can eliminate hammering when the control turns ON. The soft start setting can be found under “Power Settings” menu. The soft start can be set from 0.0 to 10.0 seconds. When using the 2 speed operation, the soft start function is active during the low to high speed transition.

11. EXTERNAL SPEED & FREQ. CONTROL

The feeder control’s power level can be controlled by an external signal from a PLC, CFR sensor, or an analog source. The “External Speed Connections” section gives connection details.

- A. When the Constant Feed Rate (CFR) sensor is used, The “Amplitude Source” and “Frequency Mode” settings should be set to “Auto Track.” The control should display “Run/CFR” showing that the sensor is connected. Set the power setting to the desired feed rate. The control uses information from the CFR sensor to maintain a constant vibration level at the resonate frequency. See the CFR instructions page for more information.

Caution: it is recommended when using the CFR feature, that the Max output level of the control should be limited to prevent the feeder coil from overheating. The amplitude could continue to increase if the system cannot get back to the desired vibration level.

- B. 4-20mA signal from a PLC can be used to remotely vary the output of the control instead of the keypad. The “Amplitude Source” setting must be set to 4-20mA to enable it. After the 4-20mA feature is selected, the control will automatically turn ON whenever a 4-20mA signal is applied to the control (TB2 “+ 4-20” & “-“). When the 4-20mA signal has been removed, the amplitude setting resets to zero.

The 4-20mA menu selection allows a PLC to control both the output Frequency and Amplitude or only the Frequency or just the Amplitude. The amplitude is controlled by the 4-20mA input. The Frequency is controlled by the 0-10VDC signal. The signal adjusts a 100Hz range. The Min Frequency adjustment specifies the frequency used when the 0-10VDC input is at 0VDC. The Max Frequency adjustment can be used to ignore the upper end of the 0-10VDC signal.

- C. 0-10VDC signal from a PLC can be used to remotely vary the output of the control instead of the keypad. The “Amplitude Source” setting must be set to 0-10VDC to enable it. After the 0-10VDC feature is selected, the control will automatically turn ON whenever a signal is applied to the control (TB2- “+0-10” & “-“). When the 0-10VDC signal has been removed, the amplitude setting resets to zero.
- D. When it is desirable to ignore the external speed control inputs, the “Manual” setting can be selected.

12. CFR Positive and Negative Gain

The CFR Positive and Negative Gain settings control the rate the feeder's vibration level is corrected by the control. When the vibration decreases below the set-point, the "CFR Positive Gain" sets the rate at which the output gets boosted to compensate for a vibration decrease. When the vibration increases, the "CFR Negative Gain" sets the rate at which the output gets lowered to compensate for a vibration increase. If either the CFR Positive or Negative gain is set too low, it will take longer than desired to get back to the original feed rate. If either gain is set too high, the control may over-shoot beyond the original feed rate. The CFR Positive and Negative Gain settings effect the control's operation when the CFR sensor is used, and the "Amplitude Control" is set to "Auto Track."

13. FREQUENCY SETTINGS

The "Frequency" menu contains the portion of the menu that controls the frequency settings. The frequency can be adjusted from 5 to 300Hz. The spring/mass ratio of the vibratory bowl determines the natural vibrating (resonate) frequency of the bowl. The control's output frequency needs to be adjusted to match the natural frequency of the bowl. The control can be manually tuned or automatically tuned. The frequency setting is displayed as "F= 120.0Hz."

The "Frequency Mode" setting selects either manual frequency adjustment or auto tracking frequency adjustment.

- A. Manually finding the resonate frequency of the bowl is much like finding a station on the AM radio band. Set the amplitude to about 30%. Then adjust the frequency across its range. The bowl should be expected to vibrate the parts at more than one spot across the frequency range. The resonate frequency is the frequency with the most vibration. Once the best feeding frequency range has been found, fine tune the frequency for the best parts movement. To increase feeder stability for parts load fluctuations, adjust the frequency down by .2 or .3Hz so that the feeder becomes slightly over-tuned.
- B. "Auto Scan" scans to locate the bowl's resonate frequency. Once auto tracking has found the resonate frequency, it can maintain the resonate frequency and amplitude of the feeder as the parts load changes. The CFR sensor is needed in order for auto tracking to operate, and "Auto Tracking" needs to be turned on under both "Amplitude Source" and "Frequency Mode" menus.
To show when frequency "Auto Tracking" is enabled,

the normal display menu will show a bold "F." When "=" is shown in bold, the control is locked onto the resonate frequency of the feeder.

- C. The frequency can be adjusted with an analog 0-10 volt input when the amplitude source setting is set to 4-20mA.

The Minimum frequency limit can protect the feeder from feeding at a low frequency if a spring or weld breaks. The Min. or Max. frequency can block out undesirable frequencies during Auto Scan. To avoid coil damage and blown fuses during an Autotune scan, the Minimum frequency should only be adjusted below the 45Hz default when the vibratory feeder has been specifically designed for operation below 45Hz.

14. Resonate Threshold Level

The "Resonate Threshold Level" setting sets the minimum level of vibration that the control considers as a resonate condition. The setting should be reduced if an "Auto Scan" cannot find the resonance frequency within two scan attempts. Adjustment is not normally needed.

15. Auto Track Dead Band

The "Auto Track Dead Band" setting controls how far the resonant frequency of the vibratory feeder can deviate before the output frequency of the control is adjusted to follow it. Decreasing the setting narrows the range, and increasing the setting makes the dead band range larger before a reaction takes place. This setting normally doesn't need to be changed.

16. SETTING THE TIME DELAYS

The ON and OFF parts-sensor time-delays are set independently for a period of 0-20 seconds. The time delay settings can be adjusted to provide the best individual response for the feeder. The time delays can be found under the timer settings menu. The flashing "=" blinks every quarter second to show when either the ON and Off delay timer is running.

17. PARTS SENSOR SETTINGS

The "I/O Interface" menu contains the portion of the menu that controls the parts sensor type and polarity.

- A. The control comes preset to AUTO to work with either an NPN or PNP sensor. If the sensor input status "S=1 or 0" indicates the input is on all of the time, set the control to either NPN or PNP to match the type of sensor being used.
- B. The control comes preset to "inverted" sensor

polarity. Set the sensor polarity to either "Normal" (through beam) or "Inverted" (proximity or retro-reflective).

18. RUN MODE SETTINGS

The "I/O Interface" menu contains the portion of the menu that controls the run mode and empty bowl logic.

- A. The control comes preset for normal on/off parts sensor operation. The following can be chosen:
 - 1) The "Constant On" feature can be used to keep the bowl running while the Aux output switches power to a device (air valve, SSR, or relay).
 - 2) The "2-Speed" feature allows the bowl to keep some vibration going to either trickle parts for weigh counting or to cut down the time to full speed when a high feed rate is needed. The parts sensor switches between high and low speed settings. Low speed is set by "Min Amplitude."
 - 3) The "high/low" function maintains the parts level between two parts sensors on the track. The second sensor (PNP) gets installed in place of the run jumper.
- B. The control comes preset with the "empty bowl timer" (or parts jam timer) disabled. Once enabled, the bowl will stop feeding when parts have not passed the sensor for the set time. The empty bowl timer can be adjusted from 5 to 255 seconds under the "timer settings" menu. Press the "1/0" key or toggle the parts sensor to restart the control. The auxiliary output can be set up to turn on a signaling device. See the section that describes the auxiliary output for more details.

19. AUXILIARY OUTPUT SETTINGS

The "Aux Output Mode" menu contains the menu that controls the auxiliary output (Aux Out) operation.

- A. The factory-default "Normal" setting allows the auxiliary output to turn on and off with the output of the feeder.
- B. The auxiliary output can be set to have its signal inverted from the output of the feeder. Set the "Aux Out" parameter to "Invert" to activate it.
- C. The auxiliary output can be set so that the alarm signal can indicate when the "Empty Bowl" timer has timed out. Set the "Aux Out" parameter to "Alarm" to activate it.

- D. The auxiliary output can be set so that the alarm signal can be inverted when the “Empty Bowl” timer has timed out. Set the “Aux Out” parameter to “Inv AI” to activate it.
- E. The auxiliary output can be set so that an air solenoid can be activated 1 second before feeding begins and continue for 4 seconds after feeding ends. This feature is helpful for parts orientation. Set the “Aux Out” parameter to “Air Jet” to activate this feature.

20. DIAGNOSTICS

- A. The first menu item under the diagnostic menu shows the software revision level.
- B. The next four items under the software revision level show certain software registers that may be helpful to a service technician while troubleshooting over the phone.

21. SECURITY SETTINGS

The “Security” menu contains the portion of the menu that controls access to the program menu settings. When enabled, the security code is a number from 000 to 999. The preset code is 123. It may be changed.

- A. The control comes with the security setting “Unlocked” so the control can be set up. The amplitude can be adjusted from the normal operating display. Press and hold “Enter” to enter the program menu and adjust the software settings.
- B. The amplitude only (Ampl. Only) adjustment allows operators to adjust the amplitude through the normal operating display, but not get to the program menu settings without the security code.
- C. The “Lock” setting locks the control from any adjustment without the use of the security code. If the security code has been forgotten, enter the security code #010, **press and hold** “Enter” until entry has been granted. Note: ignore the “Wrong Security Code” message. Once in the programming menu be sure to set the security code.

22. DEFAULT MEMORY

Occasionally it is nice to get back to a known setting. Once a feed system has been set up properly, the setting should be manually saved into the “Save Settings1” memory. If an operator disturbs the settings, the “Restore Settings1” feature can restore the control to a known good set up. When different parts are used on the same feed system, two other memory locations called “Save Setting2” and “Save Settings3” can be used for the second part. Operators can recall settings 1, 2 or 3 based on the part being used. Three memory

locations are available for software versions 1.15 and higher. The “Factory Reset” selection will put the original factory settings into the memory.

23. LANGUAGE

The run display and programming menus can be set to display in English, Spanish (Español), French (Français), or German (Deutsch).

24. OVER CURRENT PROTECTION

The control has a coarse over-current fault protection that trips when the output is above the rated current. Models 6450.3 & 6451.3 are rated 3A at 120V and 1.5A at 240V. Models 6452.3 & 6453.3 are rated 9A at 120V and 4.5A at 240V. Models 6472.3 & 6473.3 are rated 12A at 120V and 6A at 240V. Models 6474.3 & 6475.3 are rated 18A at 120V and 9A at 240V. The operator should monitor the output current to ensure that it is within the desired range. If an “Over Current” occurs, press the “1/0” key to restart the control. The operator should also monitor the temperature of the coils on the vibratory feeder. The coils should never be too hot to hold.

25. CFR Set Point

The CFR set point sets the amplitude vibration level that the control regulates to. The VF Series control adjusts the amplitude automatically to match the CFR set point. The CFR set point can be adjusted by the depression of the “UP” and “DOWN” arrows keys. Holding an arrow key down will adjust the amplitude setting instead of the CFR set point. The CFR set point can also be controlled by a 4-20mA signal (when using Version 1.26 software and greater).

The CFR set point only appears on the display when the “Amplitude Source” menu under power settings is set to “Auto Track” and the CFR sensor is attached.

26. Fault Messages

The VF-9 has error and warning messages that relate to “Over-Amps”, “Over-Temp” and Bowl out of parts timers. To clear the message or fault, press the “1/0” button twice.

WARNING:

Fuses should be replaced with Littelfuse 3AB “Fast Acting” type or equivalent of manufacturer's original value.

Mounting this control on a vibrating surface will void the warranty.

27. TROUBLESHOOTING

Basic Procedure – To ascertain whether the problem lies in the controller, take the following steps:

- A. The control must be connected to a known good load prior to testing.
- B. Make sure that the proper input power is present.
- C. Most problems can be identified when viewing the **Status Line Messages** on the LCD and the I/O status on the right column of the LCD. The normal operating LCD layout and messages are shown on the bottom of the page titled “Control Menu Layout”.
- D. If the LCD display doesn't light up, disconnect the input power, check that the fuses are good, and tighten the screw terminals. **Warning: Shock Hazard! Do not operate control with the cover open.** When the cover is open a shock hazard exists anytime the internal LED is ON.

When neither a humming sound nor any vibration can be detected in the vibratory feeder, the problem may be in the controller.

NOTE: The enclosure may feel quite warm when the load current is near full power.

Automation Devices, Inc.

7050 West Ridge Road
Fairview, PA 16415-2099
Phone: 814-474-5561

FAX: 814-474-2131 or 800-235-9382

Web Site: WWW.AUTODEV.COM

E-mail: SALES@AUTODEV.COM

Model 6450.3 & 6451.3 Dimensions

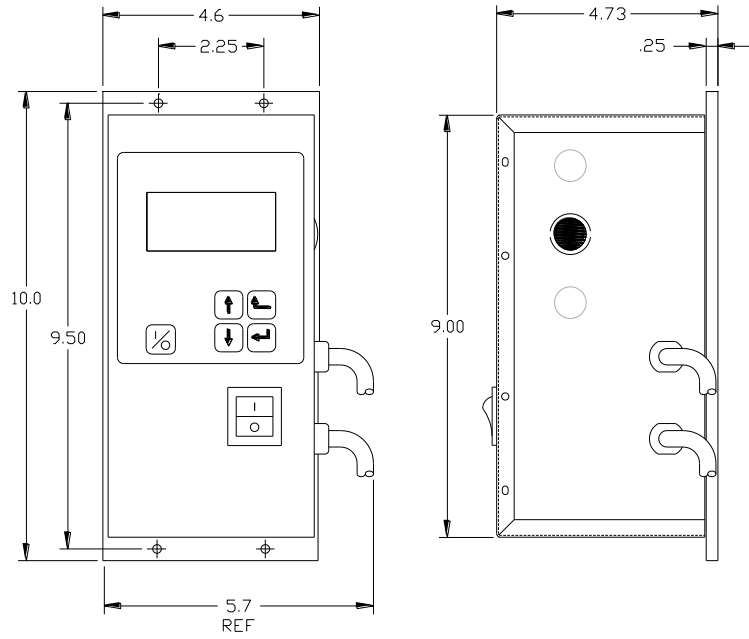

Model 6452.3 & 6453.3 Dimensions

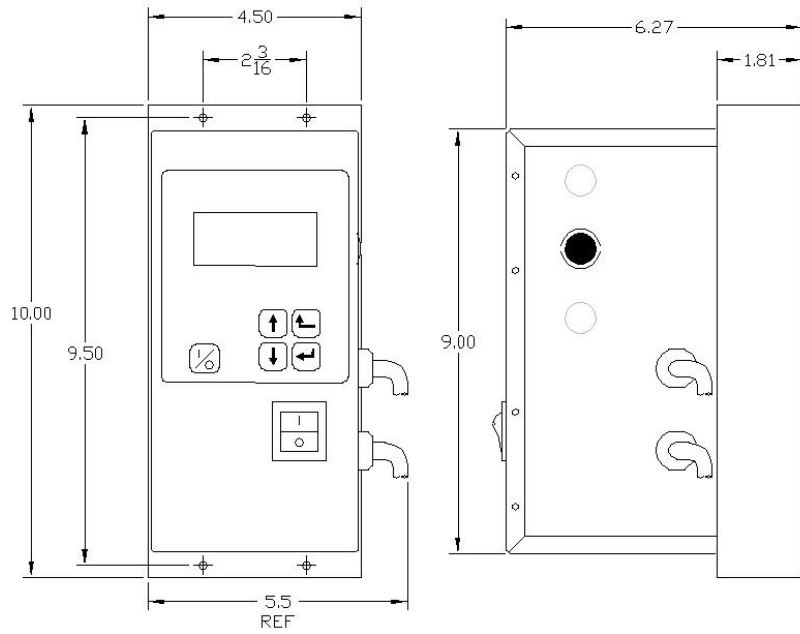



**Amplitude Controller
Model 6450 Series**

**General Purpose Models
6450.3 & 6451.3, 6452.3 & 6453.3
Variable Frequency Control
IMPORTANT INSTRUCTIONS**

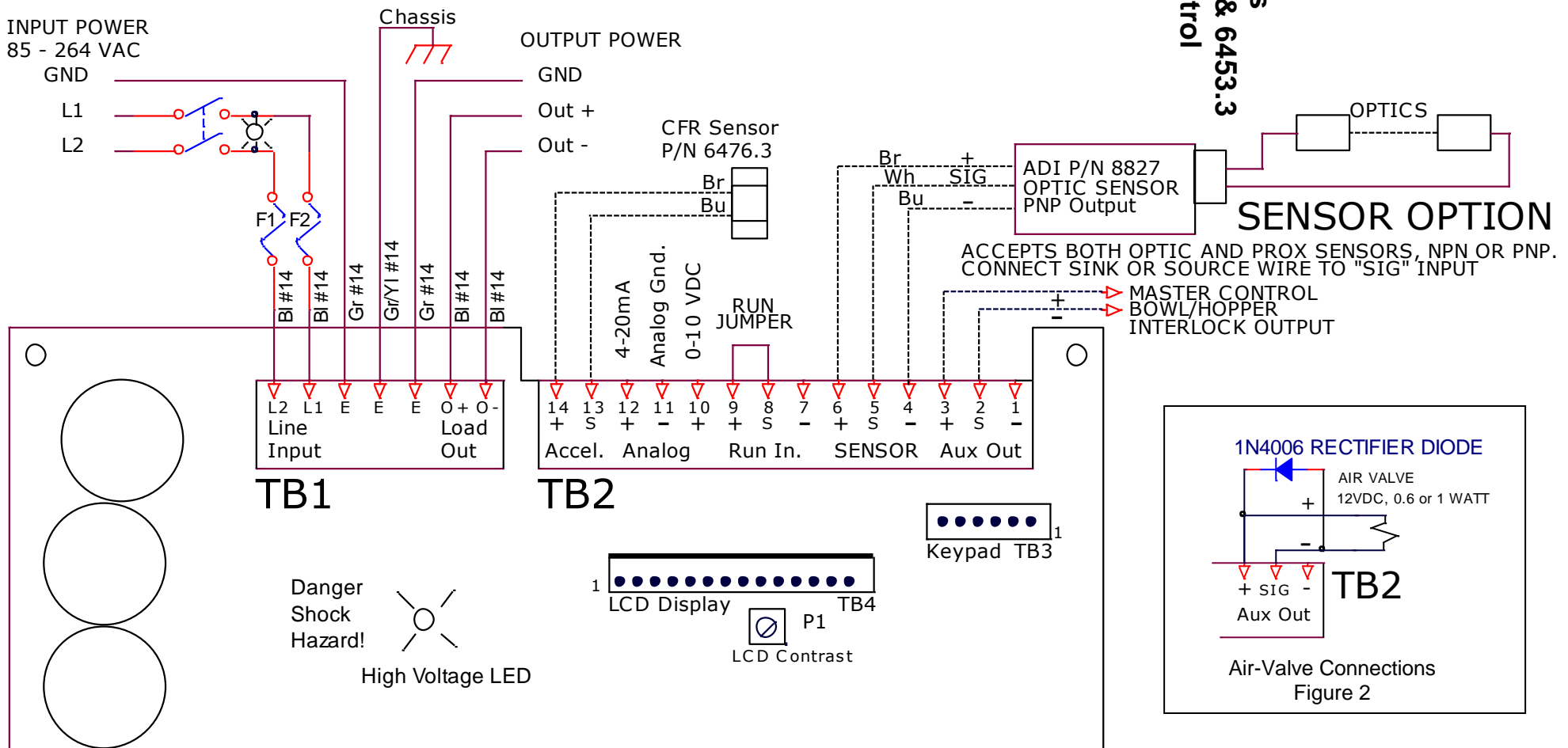

Figure 1