



Amplitude Controller Model 6000 Series



MODEL 6000.1

GENERAL PURPOSE



Input: 120 VAC
50/60 HZ.

Output: 0-120 VAC

Single Unit Fuse Size: 15 AMPS
80% Duty Cycle at Rated AMPS

Automation Devices, Inc.

7050 West Ridge Road
Fairview, PA 16415-2099
Phone: 814-474-5561

FAX: 814-474-2131 or 800-235-9382

Web Site: WWW.AUTODEV.COM

E-mail: SALES@AUTODEV.COM

ADJUSTMENTS AND SET UP

1. SELECTING OUTPUT PULSE MODE

Choose an output mode of 120 or 60 by sliding the OUTPUT PULSE DIPswitch (S1) to the appropriate position.

Other names for "120 Pulses Per Second" are AC or 7200 VPM (Vibrations Per Minute). "60" is the same as DC or 3600 VPM or Rectified.

Note: Readjust MAX pot after changing pulse mode setting.

2. LIMITING THE MAXIMUM OUTPUT OF CONTROL

Adjust the MAX Output trimpot so that the output to the feeder reaches its desired maximum level when the MAIN CONTROL DIAL is turned fully clockwise. The MAX Output trimpot should be adjusted to keep the vibratory feeder from hammering when the control is turned up to full power.

NOTE: Output to feeder must be connected and the control set for proper output frequency (60 or 120 pulse) setting. The Run Jumper must be connected as shown on the wiring diagram.

- Power input should be **OFF** or disconnected.
- Rotate **MAIN CONTROL DIAL** on front cover to 0 or its minimum setting.
- Open cover to allow access to printed circuit card.
- Using **CAUTION**, turn power **ON** (no output should be present).
- Rotate the **MAIN CONTROL DIAL** on front cover slowly to its highest setting.
- Adjust the **MAX** output trimpot so that the output to the feeder reaches its desired maximum level when the **MAIN CONTROL DIAL** is turned fully clockwise. Turning the **MAX** output trimpot clockwise increases the maximum output level.

3. REMOTE OFF/ON CONTROL

A Run Jumper has been installed at the factory as shown on the enclosed wiring diagram.

Note: TB2 terminals 5-7 are referenced to the line voltage circuit. Therefore any switch or contact connected to them must be isolated from other circuits.

Remote OFF/ON operation of the control can be configured to operate in one of the following ways.

- A low current switch such as a paddle switch can replace the factory-installed Run Jumper "J1." The "Run Contact" connects across terminals 6 and 7. The contact must be able to switch 5VDC and 2mA. The control will then run only when the contact is closed. Refer to Section A of the OFF/ON CONTROL GUIDE.
- Feeder Bowl/Hopper Interlock allows the Hopper control to operate only when the Bowl is running and the paddle switch contact is closed. The **interlock input** on terminals 11 and 12 of TB2 is controlled by the **interlock output** of a "Parts Sensing Feeder Bowl Control" such as a 6800 Series control.

Remove jumper "J1" of this control from terminals 6 and 7. Connect the Hopper Paddle switch to alternate terminals 5 and 6. Connect TB2 terminals 11 and 12 of this control to the "Parts Sensing Control". Refer to Section B of the OFF/ON CONTROL GUIDE. Check specific instructions for the "Parts Sensing Control" wiring.

Note: Only use Bowl/Hopper Interlock with a 6800 and 6000 Series control. Two 6000 Series controls will not interlock to each other since neither one has an **interlock output**.

- Low Voltage DC can be used to turn the control **ON** and **OFF**. Move jumper "J1" from terminal 7, to terminal 5, (6 remains the same). Then connect the positive signal (+10 to 30VDC @ 10mA) to terminal 12 and the negative to terminal 11 of TB2. The control will now turn **ON** when the DC signal is present at terminals 11 and 12 of TB2. This input is optically isolated. Refer to Section C of the OFF/ON CONTROL GUIDE. TB-2 terminals 5-7 are transformer isolated from the line voltage circuit.

4. SETTING THE MINIMUM OUTPUT LEVEL OF CONTROL

When the vibratory feeder is nearly empty, turn the **MAIN CONTROL DIAL** to “1” and adjust the **MIN** trimpot to just below the slowest speed that provides the proper feed rate. The **MIN** trimpot also serves as the “low speed” trimpot for 2-speed operation. See “S1 Programming Chart” for feature selection details.

5. MAIN CONTROL DIAL

The output power is controlled by the **MAIN CONTROL DIAL**. It is a logarithmic-tapered power out curve (non-linear) that spreads the power broadly across the **MAIN CONTROL DIAL**. The logarithmic taper power curve helps to give maximum “Fine Control” over the output speed of the vibratory feeder. When very precise adjustment of the **MAIN CONTROL DIAL** is needed, increase the **MIN** trimpot setting and/or decrease the **MAX** trimpot setting. For precise scaling at low amplitudes, use the linear POT taper or reduce the Max pot setting. To select a linear pot taper for the Main Control Dial, see the “S1 Programming Chart.”

6. SETTING THE SOFT-START

The start-up of the control output can be adjusted to ramp up to the desired output level instead of starting abruptly. Soft-start keeps parts from falling off the tooling, reduces spring shock, and hammering when the control turns ON; it can also simulate a paddle switch ON delay. Adjust the **SOFT** Start trimpot clockwise for the gentlest start (about a 6-second ramp up to full output). Turn the trimpot fully counter-clockwise for no soft start.

7. LINE VOLTAGE COMPENSATION

Fluctuations in the line voltage can cause a feeder bowl to vary its feed rate. The line voltage compensation feature adjusts the control's output to help compensate for fluctuations in the supply voltage. If it becomes necessary to disable this feature, set “Disable LVC” from the S1 programming chart.

8. REMOTE SPEED CONTROL

Remote control of the power level can be accomplished by the following methods:

- A. 4-20mA signal from a PLC can be used to remotely vary the output of the control instead of the Main Control Dial. The 4-20mA input is automatically in

control whenever a 4-20mA signal is applied to the control (terminals TB2-8 & 9). The Main Control dial setting is ignored whenever there is a 4-20mA signal. The 4-20mA input is transformer isolated from the power line. In an environment with high electrical noise, use a shielded cable for the 4-20mA signal. The “S1 Programming Chart” shows how change to 0-20mA speed control instead of the default of 4-20mA.

- B. A 0-5VDC Analog input signal may be applied in place of the Main Control Dial at H1. The 0-5VDC input is transformer isolated from the power line.

9. SUPPLEMENTARY FEATURES

Special supplementary software features can be enabled on the 24-210/24-211 circuit boards. The features include: *linear pot taper*, *0-20mA control*, *empty bowl timer*, *low pulse rates*, and *two speed pots*. See the S1 Switch Programming Chart. Contact the manufacturer for more information.

10. STATUS LEDs

When any of the inputs are active, the associated LED will turn ON. When the RUN input conditions are met, the RUN LED will turn ON. See section 3 and the wiring diagram's ON/OFF Control Guide for more information on how to satisfy the RUN conditions.

WARNING:

Fuses should be replaced with a Bussman ABC or Littelfuse 3AB "Fast Acting" type or equivalent of manufacturer's original value.

Mounting this control directly to a vibrating device will void the warranty.

TROUBLESHOOTING

Basic Procedure – To ascertain whether the problem lies in the controller, take the following steps:

- A. Check that the fuse is good. Disconnect the input power and tighten the screw terminals.
- B. For the control output to be on: Make sure that the proper input power is present. The **MAIN CONTROL DIAL** must be turned up or if the 4-20mA input is used, it must have over 5mA. Either the **DIRECT** LED must be lit or both

the **INTERLOCK** and **EXT VOLTS** LEDs must be lit. Anytime the output is turned on, the **RUN** LED will be ON. To light the **DIRECT** LED, a Run Jumper must be connected at TB2-6 & TB2-7. To light the **INTERLOCK** LED, a Run Jumper must connect TB2-5 to TB2-6. To illuminate the **EXT VOLTS** LED, a 10-30 VDC signal has to be present at TB2-11 & 12. See the section titled “**Remote OFF/ON control**” for more information.

- C. Connect an AC voltmeter across the **LOAD** terminals (with the **LOAD** connected) and vary the **MAIN CONTROL DIAL** from minimum to maximum. In 120 pulse mode, the output should vary from approximately 30% to 98% of the input voltage depending on the setting of the **MIN** and **MAX** trimpots. In 60 pulse mode the output should vary from 20% to around 85% of the input voltage.
- D. On new installations: If the Feeder only hums but it doesn't feed any parts, try changing the **60/120** DIP switch (S1) to the opposite position.

When neither a humming sound nor any vibration can be detected in the vibratory feeder, the problem may be in the controller.

NOTE: The enclosure may feel quite warm when the load current is in the 12-15 Amp range.

S1 Programming Chart			
Program Description	S1 Switch Positions		
	SW3	SW4	SW5
Standard Program	0	0	0
Linear Pot Taper	1	0	0
0-20mA option	0	1	0
Empty Bowl Timer	1	1	0
Disable LVC	0	0	1
2-Speed Operation	1	0	1
30/40 Pulse Operation	0	1	1
Low Voltage at “1”	1	1	1

Automation Devices, Inc.

Automation Devices, Inc.

7050 West Ridge Road
 Fairview, PA 16415-2099
 Phone: 814-474-5561
 FAX: 814-474-2131 or 800-235-9382
 E-mail: SALES@AUTODEV.COM
 Web Site: WWW.AUTODEV.COM

MODEL 6000.1 GENERAL PURPOSE MODEL INSTRUCTIONS

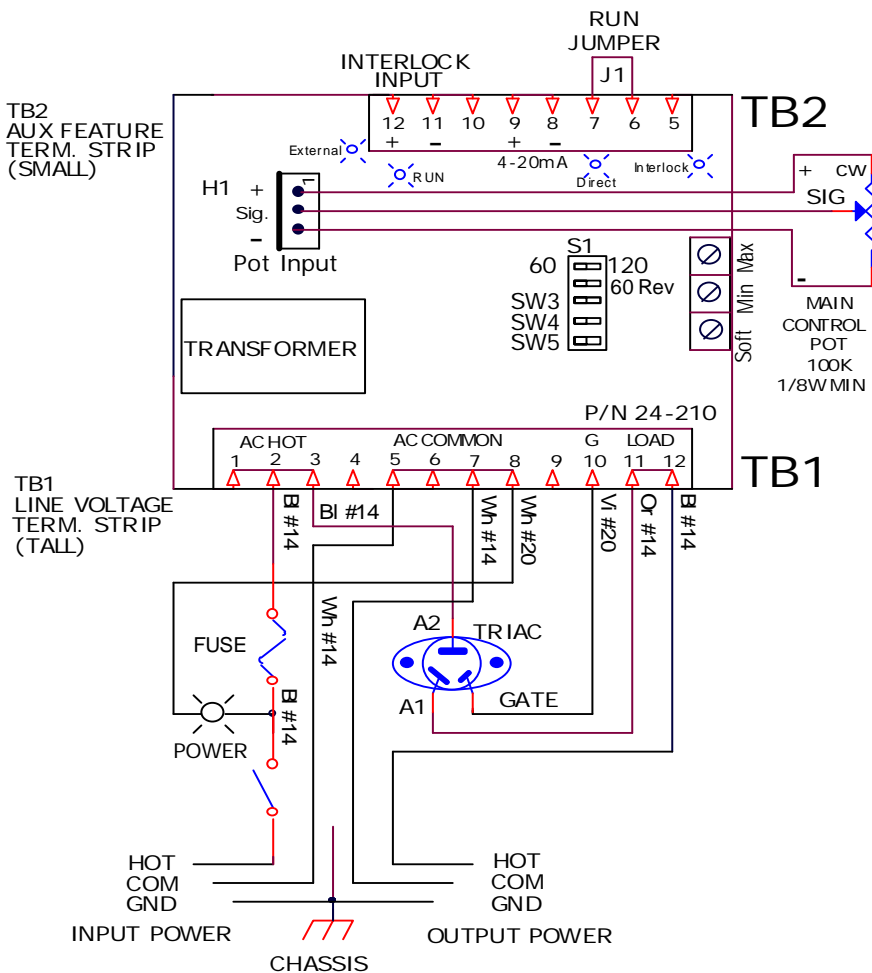
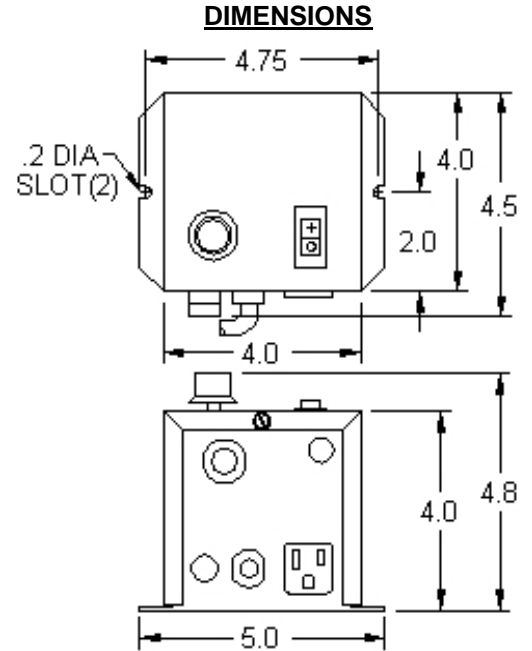

MODEL	INPUT VAC	AMPS	OUTPUT
6000.1	120VAC	15A	0-120V

OFF/ON CONTROL GUIDE

P/N 24-210/24-211

See section 3 of the Application Note for more details.

A) LOW CURRENT SWITCH

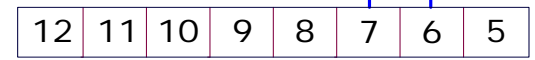

6000 SERIES TERM STRIP TB-2

B) FEEDER BOWL/HOPPER INTERLOCK

6800 SERIES
 TERM STRIP TB-2, OUTPUT

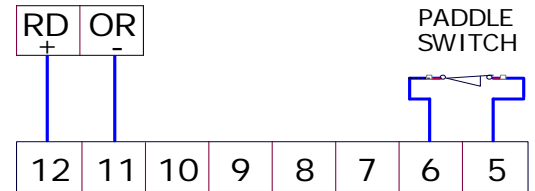

6000 SERIES TERM STRIP TB-2, INPUT

C) LOW VOLTAGE INPUT SWITCHING (DC Voltage from PLC)

10-30 VDC INPUT VOLTAGE
 OFF/ON CONTROL

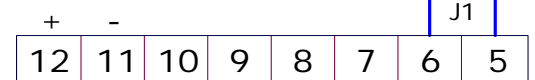

6000 SERIES TERM STRIP TB-2



Good wiring practices for avoiding electrical noise problems.

Automation Devices controls have been designed with a high degree of immunity to electrical noise; however, depending on the control installation, electrical noise can cause problems. These problems occur in less than 1% of the product installations. Most electrical noise problems can be avoided by following some simple guidelines. Good wiring practices need to be used to prevent electrical noise from interfering with your control's operation. Another name for electrical noise is Electro-Magnetic Interference (EMI).

Symptoms of Electrical Noise

The symptoms of electrical noise would appear as follows: a brief pause or a brief "bump" in the vibratory feeder's output that the control automatically recovers from. In rare cases the control will either stop operating or run continuously at full power in 120 pulse (AC) mode until the power switch is slowly cycled OFF and ON.

Sources of Electrical Noise

Electrical noise is generated by devices like relay coils, solenoid valves, contactors, servo motors, and (variable frequency inverter) motor drives. The electrical noise is then transferred to another device by one of three ways. The noise could be conducted through the power wires, or capacitively coupled from

wire to adjacent wire, or it is transmitted from the wires of a noise source.

Solutions for Electrical Noise

1. Use shielded wires for all I/O (Input / Output) signals. The I/O signals may include: Paddle switch, Run input, Interlock input. The shield "drain" wire should be tied to the chassis in the control. The drain wire should be kept shorter than 2". Please see the picture below.

Example of a "drain" wire termination

2. Never run I/O signal wires in the same conduit or raceway as AC power lines such as wires to motors, solenoids, heaters, welders and vibratory feeder controls, etc.

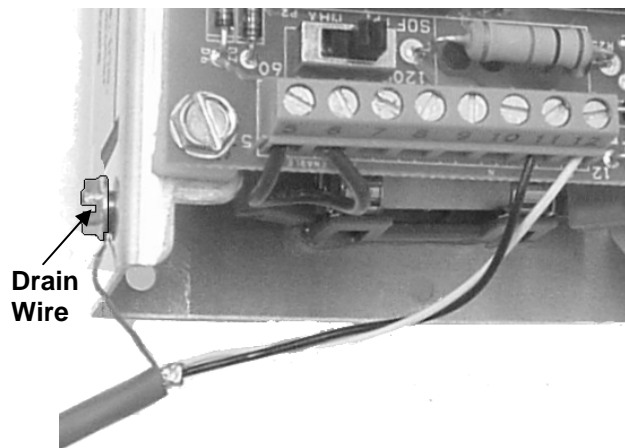

3. I/O wires within an enclosure should be routed as far away as possible from relays, solenoids, transformers, power wiring and other noisy equipment. Keep the I/O signal wires separate from the control's input and output power wiring. Secure the wires in place.

4. Whenever relays or solenoid valves are used, install a Snubber on them to reduce electrical noise. Use a diode on a DC coil. Use a RC Snubber on an AC coil.

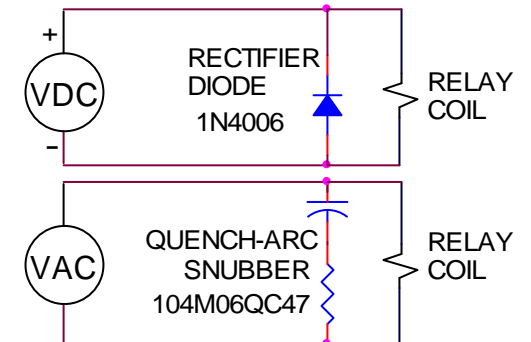

5. In extremely high EMI environments, Power Line Filters and ferrite beads can be effective. Install ferrite beads on I/O signal wires as close as possible to the circuit board terminal strip. Loop the wire through the bead several times or use several beads on each wire for additional protection.

In USA: Automation Devices, Inc.

7050 West Ridge Road
Fairview, PA 16415-2099

Phone: 814-474-5561

FAX: 814-474-2131 or 800-235-9382

Web Site: WWW.AUTODEV.COM

E-mail: SALES@AUTODEV.COM