

Automation Devices, Inc.

MODEL 15 BASE UNIT ASSEMBLY DRAWING

Parts List		
Part Number	Quantity	Description
0520	1	#10-32 x 3/8" RHSMS
1008	3	Rubber Foot
1026	1	Cable Clamp
1027	8	5/16-18 Hex Jam Nut
1028	4	5/16-18 x 1 3/4" Stud
1029	3	1/4-20 x 5/8" RHSMS
1501	1	Base Casting
1502	1	Top Casting
1503	*	Spring (1/8" Thick)
1503FA	*	Spring (3/16" Thick)
1504	*	Spring (3/32" Thick)
1504FA	*	Spring (1/4" Thick)
1505	*	Spring (3/8" Thick)
1506	**	Spring Spacer
1507	6	Spring Pad
1519	4	5/16-18 x 3/4" HHCS
1521	***	3/8-16 x 1 1/2" SHCS
1522	***	3/8-16 x 1 3/4" SHCS
1523	***	3/8-16 x 2" SHCS
1524	1	Shell
1533	3	3/16-16 Hex Nut
1611	1	120 Volt Coil
1612	optional	240 Volt Coil
1616	1	Armature
3021	***	3/8-16 x 2 1/2" SHCS
6938	1	Cable Ass'y (not shown)
8626	1	#10-32 x 3/8" Gnd Screw

* Quantity required depends on tuning for various bowl weights and operating frequency.

** Quantity required is determined by doubling the number of springs and subtracting 3.

*** Quantity required is 3 of the same length, depending on the tuning and spring combination of a particular base unit. Other lengths are not used.

When ordering replacement parts, specify the *serial number* on the unit name-plate and/or stamped on the casting.

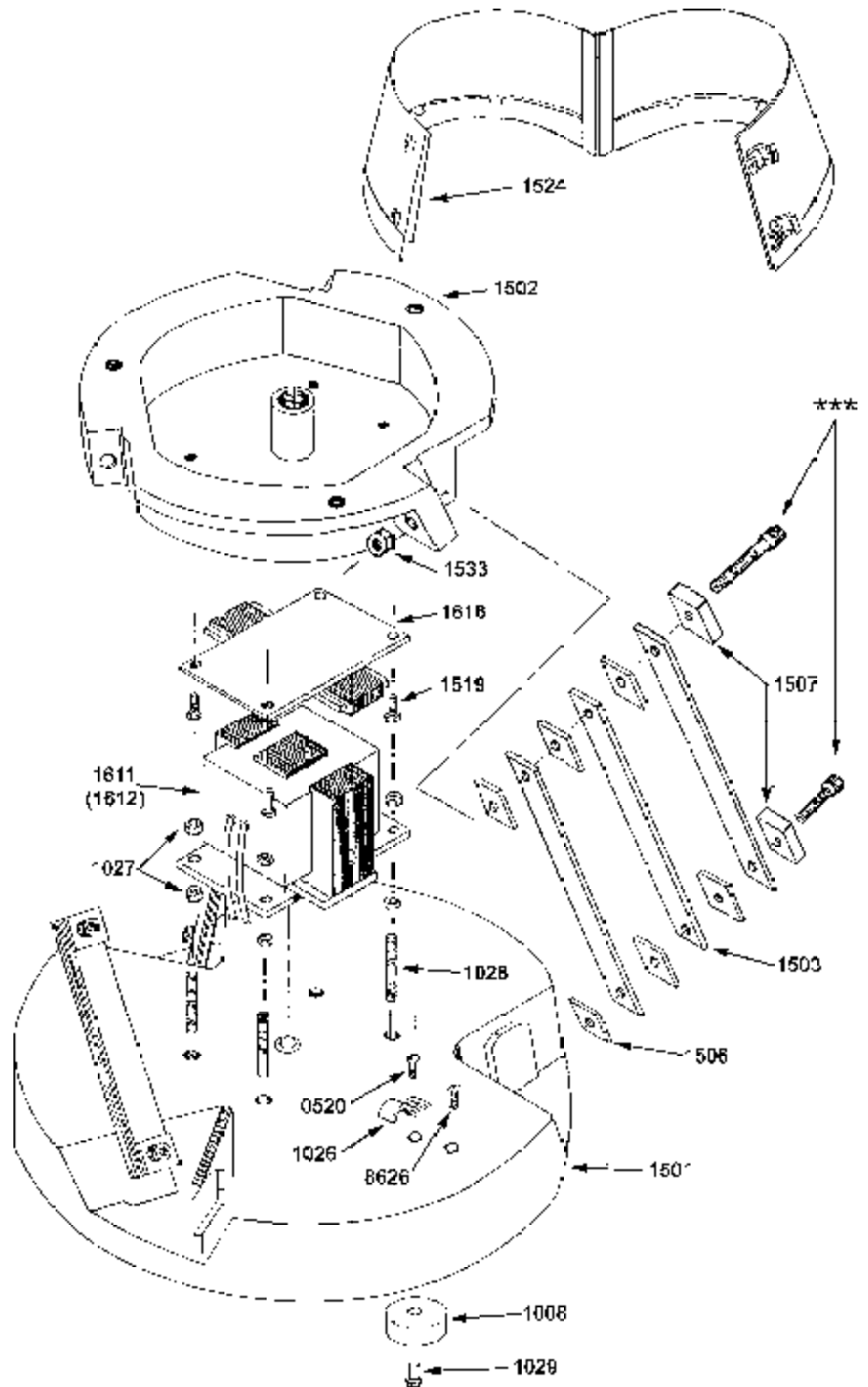

AE06.01

Automation Devices, Inc.

7050 West Ridge Road
Fairview, PA 16415-2099

Phone: 814-474-5561

FAX: 814-474-2131 or 800-235-9382

Web Site: www.autodev.com E-mail: info@autodev.com