

# Automation Devices, Inc.

## MODEL 10 BASE UNIT ASSEMBLY DRAWING

Parts List		
Part Number	Quantity	Description
0520	1	#10-32 x 3/8" RHSMS
1001	1	Base Casting
1002	1	Top Casting
1003	*	Spring (3/32" Thick)
1003FA	*	Spring (3/16" Thick)
1004	*	Spring (1/8" Thick)
1005	*	Spring (3/8" Thick)
1006	**	Spring Spacer
1007	9	Spring Pad
1008	3	Rubber Foot
1016	1	Armature
1019	4	5/16 -18 x 1/2" HHCS
1022	3	5/16 -18 x 1 1/2" SHCS
1024	1	Shell
1026	1	Cable Clamp
1028	4	5/16 -18 x 1 3/4" Stud
1029	3	1/4 -20 x 5/8" RHSMS
1033	11	5/16 -18 Hex Nut
1090	3	5/16 -18 x 2" SHCS
1111	1	120 Volt Coil
1112	optional	240 Volt Coil
8626	1	#10-32 x 3/8" Gnd Screw

\* Quantity required depends on tuning for various bowl weights and operating frequency.

\*\* Quantity required is determined by doubling the number of springs and subtracting 3.

When ordering replacement parts, specify the *serial number* on the unit nameplate and/or stamped on the casting.

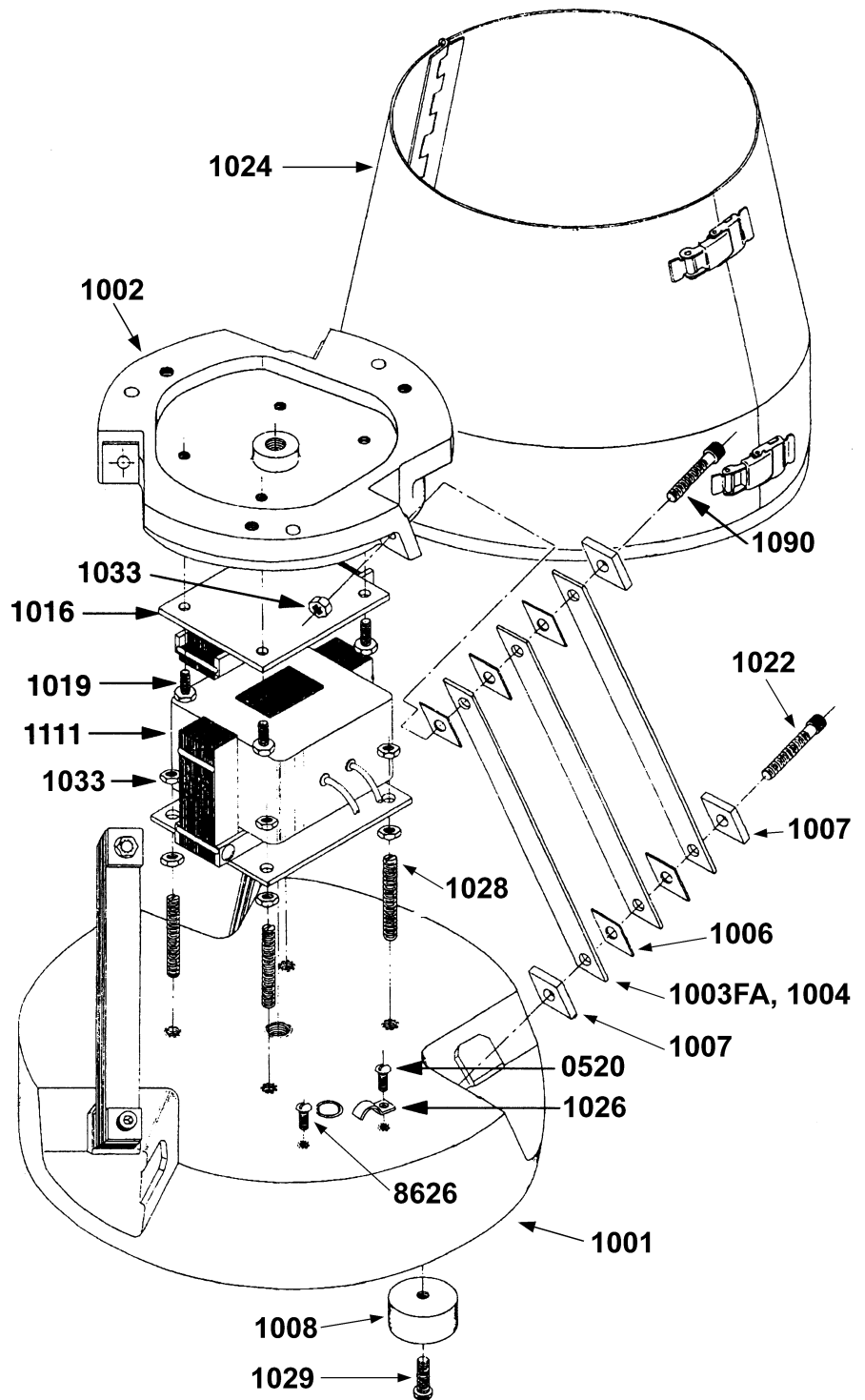

AE04.01

### Automation Devices, Inc.

7050 West Ridge Road  
Fairview, PA 16415-2099

Phone: 814-474-5561

FAX: 814-474-2131 or 800-235-9382

Web Site: [www.autodev.com](http://www.autodev.com) E-mail: [info@autodev.com](mailto:info@autodev.com)