

Automation Devices, Inc.

MODEL 10 LOW PROFILE BASE UNIT ASSEMBLY

PARTS LIST		
Part Number	Quantity	Description
0510-4	3	Double Studded Foot
1008	Optional	Single Studded Foot
0520	4	#10 - 32 x 3/8" RHSMS
0804LP	*3	Spring (.047" Thick)
1003LP	*3	Spring (.086" Thick)
1001LP	1	Low Profile Base Casting
1002LP	1	Low Profile Top Casting
1006	*12	Spring Spacer
1807	*6	Spring Pad
1012	1	3/8-24 x 1-1/4" FHSCS
1013	4	1/4-28 x 1" Set Screw
1014	3	#10 Nylon Washer
1022	3	5/16-18 x 1-1/2" SHCS
1024LP	1	Plastic Low Profile Shell
1026	1	Cable Clamp
1033	3	5/16-18 Heavy Hex Nut
1046	3	5/16-18 x 1" SHCS
1111LP	Optional	120V Coil
1118.24V	1	24V Coil

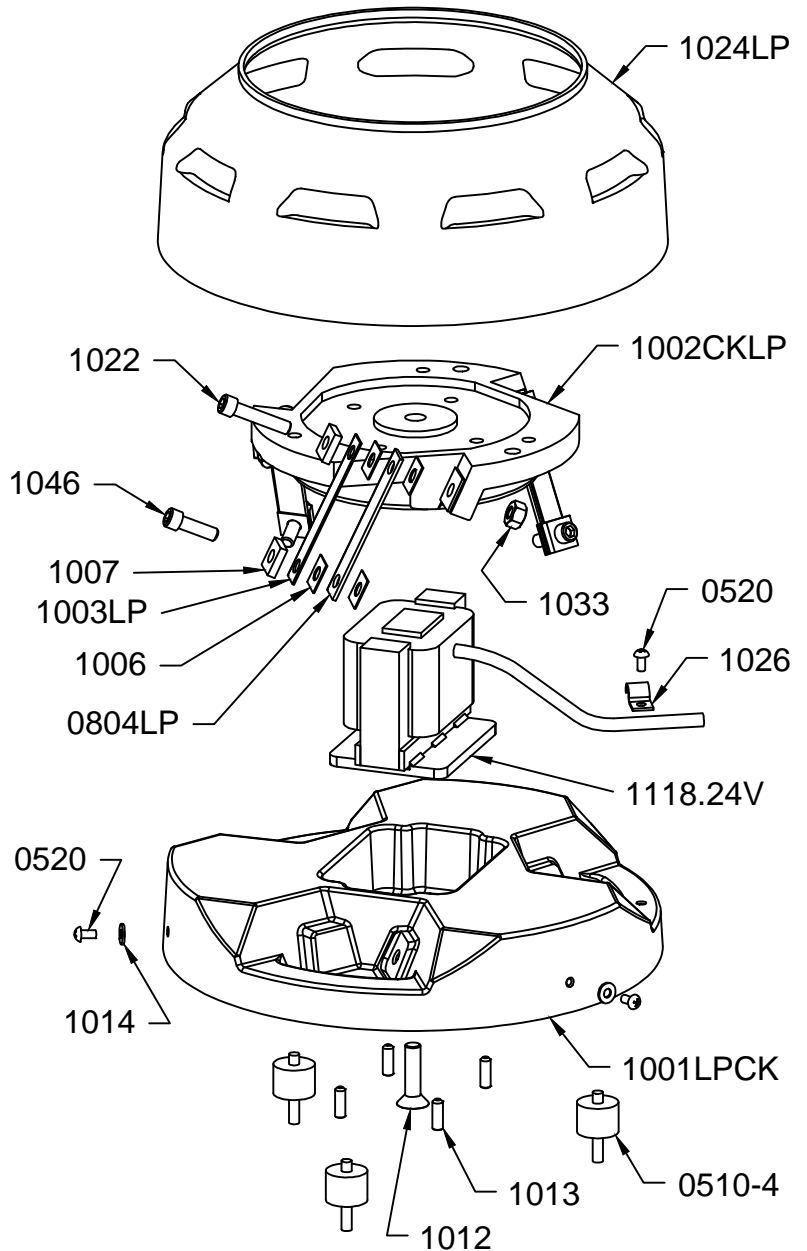

* Quantity required depends on the tuning for various bowl weights and frequency.

When ordering replacement parts, specify the serial number on the unit nameplate.

Automation Devices, Inc.

7050 West Ridge Road
Fairview, PA 16415-2099

Phone: 814-474-5561

FAX: 814-474-2131

Web Site: www.autodev.com E-mail: sales@autodev.com