



**Advanced Application Notes  
6000 Series Controllers**

**OVERVIEW:** This document covers the advanced features of the **6000 series controller circuit boards**. The circuit boards contain four (4) program jumpers that can be cut in order to enable alternate program features. The program features should be chosen based on the customer application.

**PROGRAMMING:** By cutting the correct jumper combination, it is possible to run a desired program instead of the "standard program". The four program jumpers on the circuit board are labeled A, B, C, and D. The program jumpers are actually circuit board traces located between two holes (feed-throughs). The jumpers can be cut through with a sharp knife. Care should be taken to cut the correct jumper or combination of jumpers to enable the desired program feature(s). Record which jumpers were cut by circling their letters on the label that reads PROGRAM: A B C D. The control comes from the factory configured with the "standard program." The different program variations and their descriptions are listed below:

Jumper Programming Chart	Jumper Positions			
	"A"	"B"	"C"	"D"
Program Description				
Standard Program	Normal	Normal	Normal	Normal
60 Pulse Pol. Rev. (Polarity Reversal)	Normal	Normal	Normal	Cut
Main Pot Follows Fixed Curve	Normal	Normal	Cut	Normal
Main Pot Follows Fixed Curve & Pol. Rev.	Normal	Normal	Cut	Cut
Output turns off at "0" on Main Pot	Normal	Cut	Normal	Normal
Output turns off at "0" on Main Pot & Pol. Rev.	Normal	Cut	Normal	Cut
Minimum pot is disabled	Normal	Cut	Cut	Normal
Minimum pot is disabled & Pol. Rev.	Normal	Cut	Cut	Cut
Power conservation mode w/Min pot Timer	Cut	Normal	Normal	Normal
Power conservation mode w/Min pot Timer & Pol. Rev.	Cut	Normal	Normal	Cut
Two Speed Pots w/Min pot as "Low" speed	Cut	Normal	Cut	Normal
Two Speed Pots w/Min pot as "Low" speed & Pol. Rev.	Cut	Normal	Cut	Cut
Low Pulse rate - 30 or 15 Pulse per second output	Cut	Cut	Normal	Normal
Low Pulse rate - 20 or 10 Pulse per second output	Cut	Cut	Normal	Cut
Standard Program	Cut	Cut	Cut	Normal
Standard Program	Cut	Cut	Cut	Cut

**FEATURE DESCRIPTIONS:**

**Revert Back to the Original Program:** If a program variation is attempted which does not function as desired, it is possible to revert back to the "Standard Program" by cutting jumper locations "A", "B" and "C". If needed, wire jumpers can also be installed at the Rodix factory to bypass undesired cuts.

**"60 Pulse Polarity Reversal":** Normally in the 60 Pulse (half-wave rectified) mode, the output voltage is turned on only during the bottom half of the sine wave. However with the 60 Pulse Polarity Reversal software feature, the top half of the sine wave is used instead of the bottom half.

Use this feature to reduce mechanical interaction between two vibratory feeders. Interaction occurs when both feeders use the 60 Pulse mode and they share the same machine base. This can cause the vibration from one feeder to effect the other feeder. A typical symptom of this is when turning one feeder's vibration up causes the vibration to decrease on the other one, and vice versa. To solve this problem more mass can be added to the machine base or use the Polarity Reversal feature to alter the timing on one feeder so that each feeder is pushing against the machine base at a different time. See the "Jumper Programming Chart" to see which jumper(s) needs to be cut to enable this software feature.

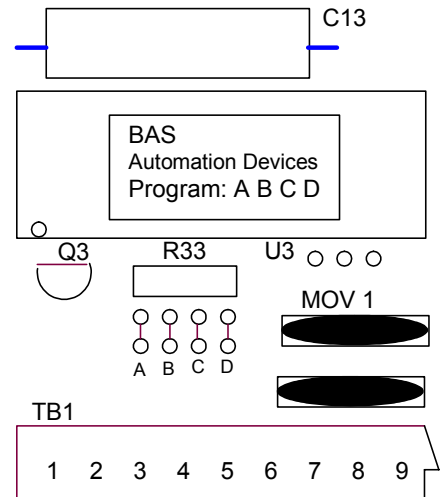

**Fig. 1 Program Jumper Location on 24-480 and 24-481 PCBs**

**“60 Pulse Polarity Reversal continued”**: A second reason for reversing the polarity of the 60 pulse waveform is to reduce the apparent power when two or more feeders are connected to the same branch of an electrical power distribution circuit. For example, on a vibratory feeder system where each unit is set to 60 pulse mode, if there is one hopper feeding at 1.5 Amps, one bowl feeding at 5 Amps, and one inline feeding at 1 Amp, then the measured current of the branch would be 7.5 Amps. But if the 60 pulse waveform were reversed on the bowl, then the apparent current of the branch would be reduced some because the current flows in both directions instead of only one. This would cause the branch step down transformer to operate a little cooler and the measured wattage at the utility meter would also decrease. See the “Jumper Programming Chart” for programming details.

**Main Control Dial Follows a Fixed Curve**: The output power is controlled by the Main Control Dial. With the standard program, a special logarithmic-tapered power out curve (non-linear) makes it easier to have "Fine Control" over the output speed of the vibratory feeder. Also, the Max trimpot setting alters the slope of the non-linear curve.

When this feature is enabled, the Main Control Dial follows a fixed curve instead of the standard non-linear curve. This feature is used when it is desirable to have the numbers on the Main control dial indicate an actual power setting. (Where "7" on the dial is meaningful).

When the fixed curve program is used, the MAX trimpot limits the effective range of the Main control dial. The MAX trimpot creates a dead band at the top end of the Main control dial so that increasing the Main control dial does not increase the output power of the control. When the fixed curve program is used, the MIN trimpot is automatically disabled. Caution – This program makes it harder to precisely adjust the Main control dial. See the “Jumper Programming Chart” for programming details.

**Output Turns Off at “0” on Main Pot**: With this software feature enabled, the Main pot can be set to zero when no vibration is desired. This can be done instead of turning the power switch off. This may be handy when clearing a part jam or when manually removing parts from a feeder during a change over to a different part. The MIN trimpot serves to set the minimum power level at “1” on the dial. The Main pot turns up from there until “10” on the dial, which is set by the MAX trimpot.

**MIN Trimpot Disable**: When it is not desirable to use the Minimum trimpot, it can be turned fully counter clockwise, or its operation can be disabled. See the MIN trimpot disable on the “Jumper Programming Chart”.

**“Power conservation mode with Min Pot Timer”**  
Use this in applications where an interlock output or a relay contact is used to frequently turn off the output of the control. When the vibratory feeder is turned on continuously longer than the time delay set by the MIN trimpot, a problem exists such as a parts jam, or the vibratory feeder is out of parts. Since a problem exists, the output is turned off after a time delay to conserve power or to prevent parts/feeder wear. When this feature is used, the MIN trimpot function is converted to the “power conservation timer.” The MIN trimpot now sets a variable time delay for .03 - 8 minutes. To restart the control, cycle it OFF and then back ON again at either the RUN input (J1 at terminals 6&7), or the Auxiliary input (TB2-11&12). Or turn the Main pot to zero and back up again. See the “Jumper Programming Chart” for programming details.

**“Two-Speed Pot operation”**: Some vibratory feeder applications need to operate at two different speeds. For example: Nail feeders operate at low speed while starting up the machine, and then switch to high speed for normal operation. Packaging machines operate at high speed while filling the package, when the package is nearly full they switch to low speed to accurately finish filling it.

For the two-speed operation, the Main Pot becomes the Normal speed pot, and the MIN trimpot becomes the Low speed pot. When this feature is used, the MIN trimpot no longer controls the minimum power level of the control. See the “Jumper Programming Chart” for programming details. The control can be signaled by two different methods to switch between the Low and Normal speed pots.

An Electrical contact can signal the control when to switch between low and normal speeds. Low speed is obtained when terminals TB2-5&6 are connected. Normal speed is used when both TB2-5&6 and TB2-6&7 are connected. The output is OFF when terminals TB2-5&6 are not connected.

A Voltage signal can signal the control when to switch between low and normal speeds. Low speed is obtained when terminals TB2-5&6 are connected and there is no voltage present at the Interlock Input, TB2-10, 11,12. When a voltage signal is properly applied at the Interlock Input, the Normal speed is enabled. The voltage signal can be 5-30VDC or 105-250VAC. See the ON/OFF control guide for TB2-10, 11,12 wiring details. The output is OFF when terminals TB2-5&6 are not connected.

**“Low Pulse rate” – 30, 20, 15, or 10 Pulse per second output:** With 60 Hz input power, this option allows the control to produce frequencies of 30, 20, 15, and 10 PPS. (For 50 Hz input power, the frequencies are 25, 16.6, 12.5, and 8.3 PPS). Vibratory feeders with large parts, large tray feeders and a few inline track applications may operate below 60 PPS. A vibratory feeder that is converted to a lower pulse mode will require fewer springs.

The theory behind the “Low Pulse Rate” option is that the output of the control can be turned ON and OFF to simulate the desired low frequency waveform. Current flows through the vibratory feeder electromagnet coils during the ON time, and the coils are OFF the rest of the cycle. The output frequency depends on how long it takes to complete one ON and OFF cycle. To simulate the desired frequency, the output is turned on (ON time) for a series of 60 Hz pulses, and then it is turned off (OFF time) for the same amount of time. An example of this is shown in the waveform titled “Current Waveform, 10Hz. One second is shown in this window”. Since the vibratory feeder is tuned to a resonate frequency, it is stimulated by the desired frequency, but it is unable to respond to the higher 60 Hz modulating frequency.

Simulating 30 Hz or lower with Alternating Current (AC) instead of using Direct Current (DC) will decrease the amount of work that is done by the vibratory feeder coils, which will decrease the feed rate of the machine. This is because the output of the control provides AC, and not DC. DC provides more power than AC during the same amount of time. This is because Direct Current is flowing during the entire ON time, however Alternating Current isn't flowing as much of the time because it periodically goes to 0 amps. The coil size and the coil gap determine the maximum current draw of the vibratory feeder system. When sizing a distribution transformer for this control, the transformer will need to be oversized.

Operation: See the “Jumper Programming Chart” for programming details. Jumper "D" selects which frequency range to use, 30/15 Hz or 20/10 Hz. Next, the pulse mode is selected with the 60/120 switch.

**Pulse mode selection:**

For the 30 Hz/15 Hz range, select 120 on the 60/120 switch for 30 Hz and 60 for 15 Hz.

For the 20 Hz/10 Hz range, select 120 on the 60/120 switch for 20 Hz and 60 for 10 Hz.

During the initial operation of the control on the machine it is important to monitor the temperature of the coils on the vibratory feeder. If the coils become too hot to touch, the coil current is too high. Decrease the MAX pot setting and re-apply power after the coils have cooled. Overheating the coils will eventually cause them to short circuit and fail.

**Low Pulse Rate Waveforms that produce 10HZ**

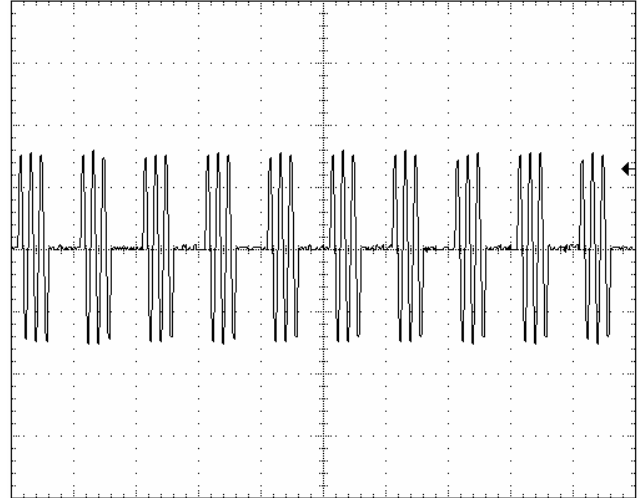

**Current Waveform, 10Hz.**

One second is shown in this window. The Off/On cycle repeats 10 times per second to provide 10Hz.

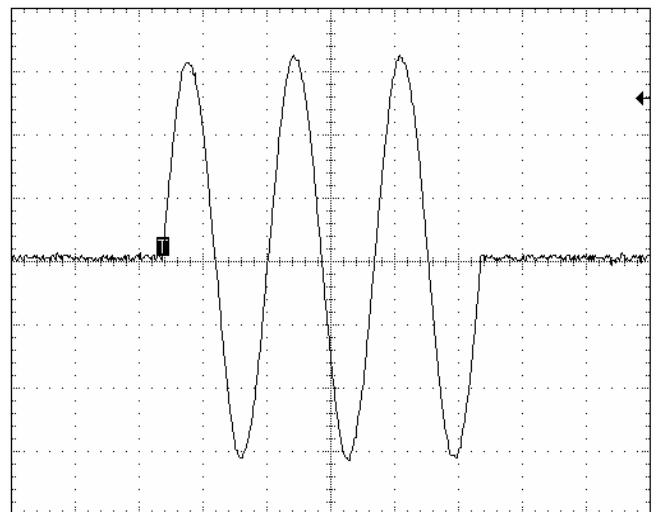

**Enlarged Current Waveform**

0.1 Second is shown in this window. The current is on for 3 sine waves then off for 3 sine waves.

**INPUT VOLTAGE:** The 24-480 circuit board will operate from 90-120VAC +/- 10%. The 24-481 circuit board will operate from 180-240VAC +/- 10%.

**NOISE IMMUNITY:** For further details about noise immunity, see the application note for your model in the instructions and the Automation Devices Good Wiring Practices for Avoiding Electrical Noise Problems.

**In USA: Automation Devices, Inc.**

7050 West Ridge Road  
 Fairview, PA 16415-2099  
 Phone: 814-474-5561  
 FAX: 814-474-2131 or 800-235-9382  
 Web Site: [WWW.AUTODEV.COM](http://WWW.AUTODEV.COM)  
 E-mail: [SALES@AUTODEV.COM](mailto:SALES@AUTODEV.COM)