

PNP Manual-Calibration #8827

Fiber optic Sensor Instruction Manual

Major Features and Functions

1. Ultra-long detecting distance

When the selector switch is set to TURBO, the 8827 provides approximately double the detecting distance.

2. Fine adjustment

The detecting distance changes linearly according to the number or trimmer of turns

Warning!

The 8827 are intended for target detection. Do not use these products in a safety circuit for protecting the human body. The 8827s are not explosion-proof. Do not use these products in an atmosphere where inflammable gas, liquid or powder is present

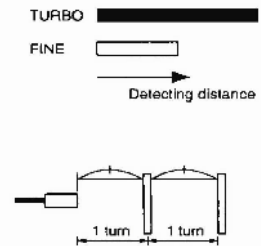

Structure and Part Names

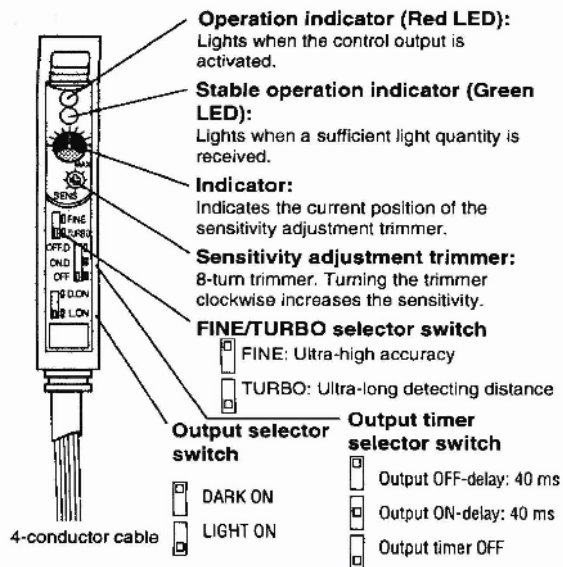

Accessories

Instruction manual (x 1)



Resin screw-driver (x 1)

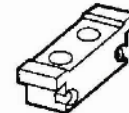

Mounting bracket (x 1)

Specifications

Model	8827
Light source	Red Led
Sensitivity adjustment/ Mode Selection	8-turn trimmer (with indicator) / FINE/TURBO switch-selectable
Response time	250 μ s (FINE), 500 μ s (TURBO)
Operation mode	LIGHT ON/DARK ON (switch selectable)
Indicators	Output indicator: Red LED, Stable operation indicator: Green LED
Timer function	ON-delay: 40 ms, OFF-delay: 40 ms, Timer OFF (switch-selectable)
Control Output	PNP open collector 100 mA max (40 V max.) Residual voltage: 1 V max.
Stability Output	PNP open collector 50 mA max (40 V max.) Residual voltage: 1 V max.
Protection Circuit	Reverse polarity protection, Over current protection, Surge protection
Power supply voltage	12 to 24 VDC \pm 10%, Ripple (P-P) 10% max.
Current Consumption	35 mA max.
Ambient illumination	Candescant lamp: 10,000 lx max. Sunlight 20,000 lx max.
Relative humidity	35 to 85%. No condensation
Vibration	10 to 55 Hz, 1.5 mm double amplitude in X, Y and Z directions for 2 hours
Shock immunity	500 ms/s in X, Y and Z directions, three times each
Housing Material	Body/Cover: Polycarbonate
Weight (including 2 m cable)	Approx. 75 g

Connections

To connect the 8827 to a voltage input device, provide a 4.7k Ω resistor between the blue and black or orange cables.

When the stability output is not used, cut the orange cable at the root, or connect this cable to the positive terminal of the power supply.

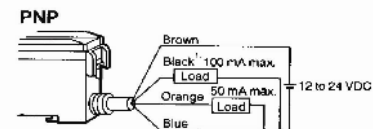

Setting Sensitivity

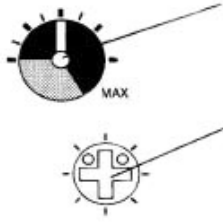

Indicator: Indicates the current position of the sensitivity adjustment trimmer. One turn of the trimmer changes the pointer position by one division on the indicator scale.

Sensitivity adjustment trimmer (8-turn): Turning the trimmer clockwise increases the sensitivity. Turning the trimmer counterclockwise decreases the sensitivity.

Note:

- Do not turn the trimmer until the pointer exceeds the indicator's transparent window range. If the trimmer is turned more than the specified number of times, the pointer position may be displaced by approximately one division, although the trimmer will not be damaged.
- The pointer position varies depending on the characteristics of each unit. Adjust the sensitivity using the individual amplifier.
- Depending on the combination of the amplifier and fiber unit, the trimmer may not be turned 8 times.

To detect presence absence of a target

1. Set the selector switch to the L.ON mode.
 2. Set the sensitivity to the minimum. (Turn the trimmer so that the pointer is within the transparent window range.)
 3. With a target in place, turn the Sensitivity Adjustment Trimmer clockwise. Find point A at which the operation indicator (red LED) lights.
 4. When the operation indicator (red LED) is unlit with no target, turn the Sensitivity Adjustment Trimmer clockwise to find point B at which the operation indicator lights. When the operation indicator (red LED) is lit with no target, turn the Sensitivity Adjustment Trimmer counterclockwise to turn off this indicator. Then, turn the trimmer clockwise to find point B at which the operation indicator lights.
 5. Set the sensitivity to the midpoint between points A and B.
 6. After sensitivity adjustment, select the L.ON or D.ON mode depending on whether the sensor is to be turned on or off when a target is in place.
- When the sensitivity difference is smaller than one division on the indicator scale, adjust the sensitivity based on the position of the sensitivity adjustment trimmer. If there is a difference of at least half a turn between points A and B, stable detection is possible.

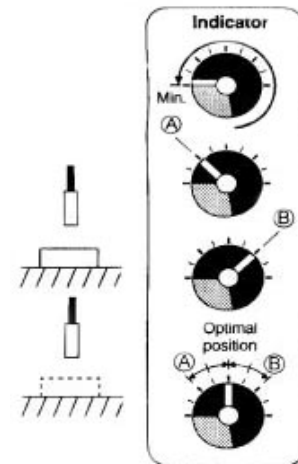

Selecting FINE/TURBO Mode

FINE mode:

- For detection of a minute difference, or highly accurate positioning
- Response speed: 250 μ s

TURBO mode:

- Used when detecting distance provided in the FINE mode is insufficient, for detection of long distance, or detection of a target with low reflectivity
- Response speed of 250 μ s

Note: After switching the FINE/TURBO mode, be sure to readjust the sensitivity.

Self-diagnostic function

When the received light quantity exceeds the detection level but does not exceed the stable operation level “31 times continuously” or “for 8 seconds continuously” the stability output is activated.

Reset: When the stability output is activated, clean the front surface of the fiber unit or re-align the optical axis so that the stable operation indicator (green LED) lights again. The stability output is reset when detection is done the stable operation indicator (green LED) is turned on.

Mounting Amplifier

Mounting/Detaching the amplifier to/from a DIN rail or the mounting bracket.

Hook the claw located at the amplifier cable side onto the DIN rail, and then hook the front side claw to the rail while pressing the amplifier forward. To detach the amplifier, unhook the front claw by lifting the amplifier front side while pressing it forward.



Side mounting

Using the side holes of the supplied mounting bracket, fix the amplifier with screws.

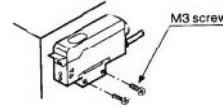

Connecting Fiber Unit

Tilt the quick-release lever, insert the fiber unit until it stops, and then lift the quick-release lever.

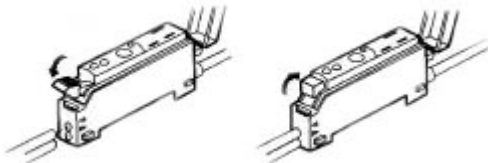

Note. If the fiber unit is improperly connected, the sensor cannot meet the specifications.

I/O Circuit

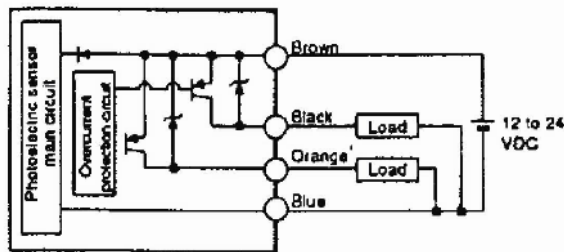

1. When the stability output is not used, cut the orange cable at the base, or connect this cable to the positive terminal of the power supply.

Hints on Correct Use

- If the amplifier cable is placed together with power lines or high-voltage lines in the same conduit, detection error may occur due to noise interference, or the sensor may be damaged. Isolate the amplifier cable from these lines
- When using a commercially available switching regulator, ground the F.G. terminal and ground terminal.
- Do not use the 8827 Series outdoors, or in a place where extraneous light can enter the light receiving surface directly.
- During maximum sensitivity setting, the detecting distance may vary due to the difference in characteristics of each unit.
- If the wiring is incorrect, the unit may heat up, or the sensitivity setting may fluctuate. (See "Connections" on p.1)
- When the stability output is not used, cut the orange cable at the root, or connect this cable to the OV terminal of the power supply.*
*When cutting the cables at the root, be sure not to contact other cables.

Dimensions

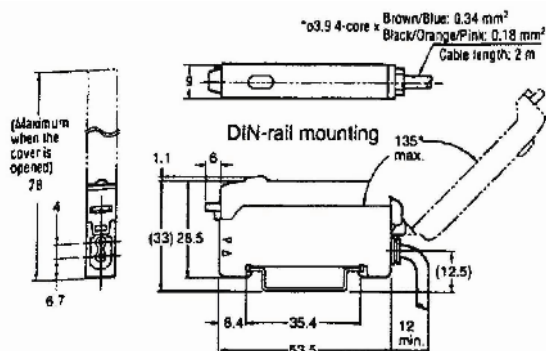

Automation Devices, Inc.
814-474-5561
7050 West Ridge Road
www.autodev.com
Fairview, PA 16415

Created with

 **nitroPDF** professional

download the free trial online at nitropdf.com/professional

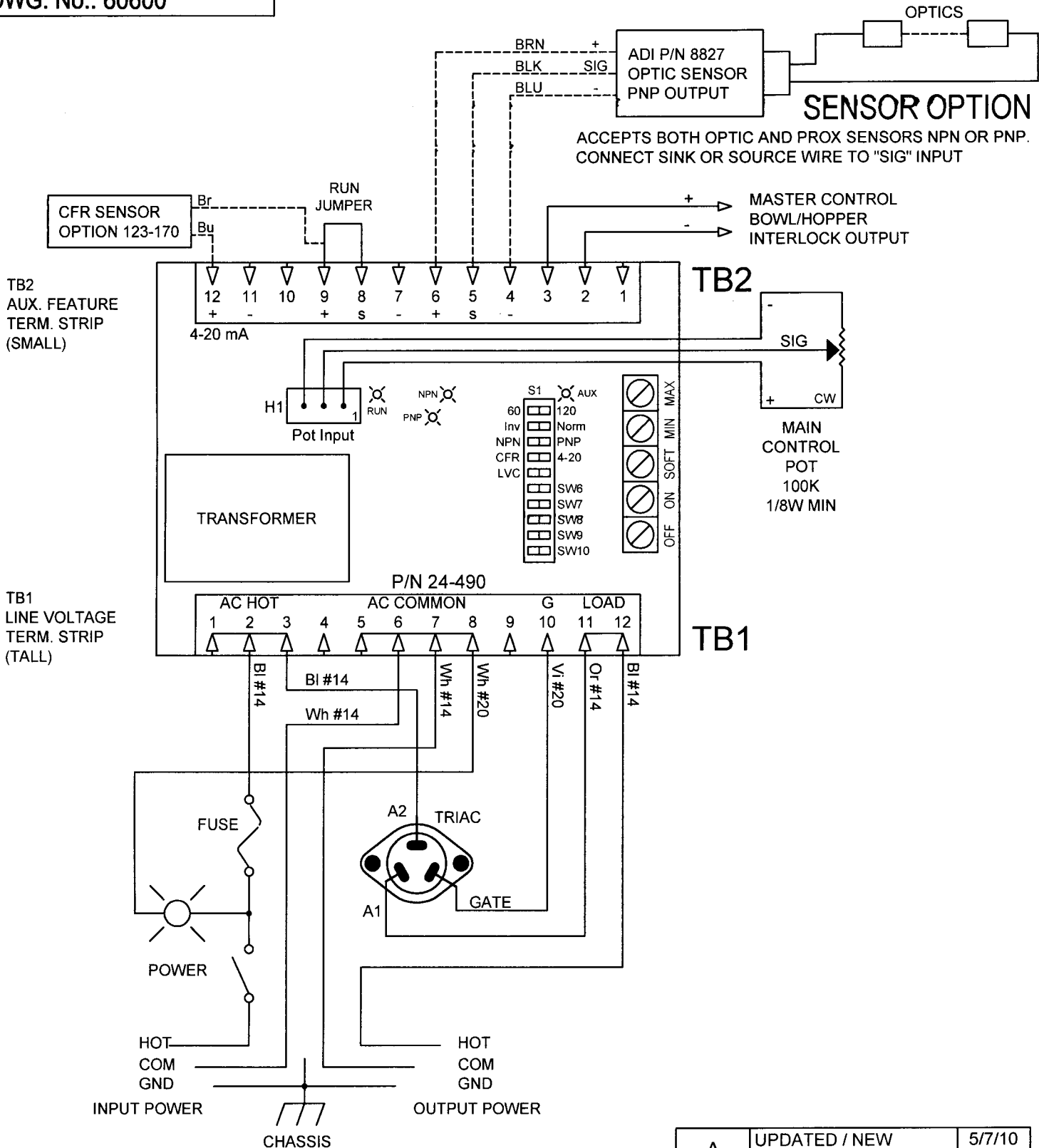

DRAWING TITLE: Wiring Diagram

FOR: 6800.1 with 8827 Sensors

SCALE: None DRAWN BY: JP DATE: 6/5/2009 APPROVED BY: DATE:

AUTOMATION DEVICES, INC.

7050 WEST RIDGE ROAD FAIRVIEW, PA 16415-2099
 PHONE: 814-474-5561 FAX 814-474-2131
 www.autodev.com

A	UPDATED / NEW CONTROLLER	5/7/10
LTR	REVISIONS	DATE INIT
TOLERANCE UNLESS OTHERWISE SPECIFIED		
DECIMAL: .00 ±.015 .000 ±.005		
FRACTIONAL: ± 1/64 ANGLES: ± 1/2°		
- DO NOT SCALE DRAWING -		
MATERIAL:		
PART No.:		

DWG. No.: 60600