

"Feeding the World's Appetite for Productivity"

# Automation Devices, Inc.

In USA: Automation Devices Inc.  
 7050 West Ridge Road  
 Fairview, PA 16415-2099  
 Phone: 814-474-5561  
 Fax: 814-474-2131  
 Web Site: www.autodev.com  
 Email: sales@autodev.com

## REOVIB MTS 440, 441, 442

### Overview



REOVIB MTS 441



REOVIB MTS 442

One and two channel control units for full and half wave feeders..  
 Efficient control of feeder throughput by controlling the supply voltage using phase-angle control.  
 All settings are made externally using a touch panel and LED display.  
 The feed rate is held constant irrespective of supply voltage variations.  
 Functions include:  
 Soft-start, soft-stop, maximum limit setting, vibrating frequency 50/100 Hz (60/120 Hz)  
 Start/Stop input, status output, track control, solenoid valve output (air blast).  
 Internal interlocking; channel 1 inhibits channel 2 or channel 2 inhibits channel 1 (MTS 442 only).

Technical Data:	MTS 440	MTS 441	MTS 442
Supply voltage:	115 / 240 V, 50/60 Hz		
Output voltage:	0...100 / 0...210 V		
Output current:	10 A	6 A	6 A (10 A total)
Enable input:	24 V, DC or Contacts		
Track sensor:	24 V, PNP		
Status output (ON/OFF):	24 V, DC / 20 mA		
Solenoid valve output:	24 V, DC 100 mA		
Operating temperature:	0... + 45 °C		
Storage temperature:	-10...+ 80 °C		
Recommended fuse:	16 A		

### Display and controls



- Increase value
- Decrease value
- Go Back
- Programming mode or Enter

### Instructions:

Menus are used for changing settings. The different parameters are selected by entering a code.

All adjustments are made by firstly pressing the P key, followed by selecting the entry code, using the cursor keys.

### Settings

Pressing the cursor key for a short time causes a unit increment/decrement, holding down for a longer time gives changes in tens of units.

Setting changes are saved upon leaving the menu or automatically if a key is not pressed for 60 seconds.

### Running Displays

Channel 1		Set point in %
Channel 2		Set point in %
		Enable OFF
		Track full
<input checked="" type="radio"/>		Timer running
<input type="radio"/>		Stop using "0" key
		Sensor time out
		Powering up

## Functions summary

Setting	Range	Code	Factory setting	Menu code	Setting	Range	Code	Factory setting	Menu code
Feed rate channel 1	0... 100 %	o	0 %	000, 020	Sensor time out time	30... 240 Sec.	E.E.	5 Sec.	015
Feed rate channel 2	0... 100 %	i	0 %	000, 021	440/ Sensor logic AND	0 / 1	SLA	0	014
2. Set point (Coarse) channel 1	0... 100 %	2.	0 %	000, 020	442 Sensor logic ExOR	0 / 1	SLE	0	014
External set point	0 / 1	E.S.P.	0	003	Pulsed operation channel 1	0 / 1	o. HP.	0	004
Set point Potentiometer	0 / 1	POT.	0	003	Pulsed operation channel 2	0 / 1	i. HP.	0	004
Set point 0(4)... 20 mA	0 / 1	4.20		003	Pulse ON	0... 60 Sec.	H.	2 Sec.	004
Maximum limit channel 1	50...100 %	g	100 %.	020	Pulse OFF	0... 60 Sec.	h.	2 Sec.	004
Maximum limit channel 2	50...100 %	z	100 %.	021	Channel 1				
Vibrating frequency channel 1	0 / 1	o. HA.	0	020	Coarse / fine control active	0 / 1	S.P.2	0	003
Vibrating frequency channel 2	0 / 1	o. HA.	0	021	Interlocking				
Soft start channel 1	0... 10 Sec.	o ./.	0.1 Sec.	020	442 Channel 1 inhibits channel 2	0 / 1	o.-i.	0	003
Soft start channel 2	0... 10 Sec.	i. ./.	0.1 Sec.	021	442 Channel 2 inhibits channel 1	0 / 1	i.-o.	0	003
Soft stop channel 1	0... 10 Sec.	o. \.	0,1 Sec.	020	Air valve function	0 / 1	A.i.r.	0	003
Soft stop channel 2	0... 10 Sec.	i. \.	0,1 Sec.	021	Save user settings	PUSH.			143
Invert enable channel 1	0 / 1	o.-En.	1	020	Invert enable channel 1	0 / 1	o -En.	0	020
Invert enable channel 2	0 / 1	i.-En.	1	021	Invert enable channel 2	0 / 1	i -En.	0	020
Switch on time delay channel 1	0... 60 Sec.	o. l.	5 Sec.	007	Restore factory settings		FAC.		210
Switch on time delay channel 2	0... 60 Sec.	i. l.	5 Sec.	006	Restore user settings		US.PA.		210
Switch off time delay channel 1	0... 60 Sec.	o.O.	5 Sec.	007	Hide programming menus		Hd.C.		117
Switch off time delay channel 2	0... 60 Sec.	i.O.	5 Sec.	006					
Invert sensor channel 1	0 / 1	o. -SE.	0	007					
Invert sensor channel 2	0 / 1	i. -SE.	0	006					

No code number is required to change the feeder throughput: pressing the P key twice will call up the set point display.

**Code 000 Feed rate set point**

**Feed rate settings**

Symbol for channel 1

Symbol for channel 2

## Safety Instructions

This description contains the necessary information for the correct application of the product described below. It is intended for use by technically qualified personal.

Qualified personnel are persons who, because of their training, experience and position as well as their knowledge of appropriate standards, regulations, health and safety requirements and working conditions, are authorised to be responsible for the safety of the equipment, at all times, whilst carrying out their normal duties and are therefore aware of, and can report, possible hazards (Definition of qualified employees according to IEC 364)



### Warning!

Hazardous Voltage

Failure to observe can kill, cause serious injury or damage

Isolate from mains before installation or dismantling work, as well as for fuse changes or post installation modifications.

Observe the prescribed accident prevention and safety rules for the specific application.

Before putting into operation check if the rated voltage for the unit conforms with the local supply voltage.

Emergency stop devices must be provided for all applications. Operation of the emergency stop must inhibit any further uncontrolled operation.

Electrical connections must be covered.

The earth connection must be checked, for correct function, after installation.

## Installation

<b>Check !</b>	<p>Are the supply, feeder coil and controller input voltages correct ?</p> <p>Is the controller adequately rated for the rated power of the feeder ?</p> <p>What is the vibrating frequency of the feeder ?</p>
<p>Connect the unit in accordance with the wiring instructions and ensure that earthing is correct !</p>	
<b>! Tip</b>	<p>New units are factory set (see table for settings).</p> <p>For units with unknown settings, first recall the factory settings using Menu C 210 FAC..</p>
External Setpoint.	<p>When an external set point source is used (MTS 441) select Menu C 003 E.S.P. = I and if a potentiometer is used select Pot = I.</p> <p>To set the minimum vibration level, select E.S.P. = 0, adjust the vibration level with the cursor keys and then select E.S.P. = I.</p>
	<p>The specific settings for the system can be saved using Menu C 143 US.PA. (recalled using C 210 US.PA).</p> <p>Menus can be hidden by selecting C 117 Hd.C.= 1.</p>

### Code 003 Function settings

P     P  
 P     P  
 P     P  
 P     P  
 P     P  
 P     P  
 P     P  
 P     P  
 P     P

0 = Set point using display  
 1 = external set point 0...+10 V ON  
 0 = external set point 0...+10 V  
 1 = external 4...20 mA  
 0 = 0...10 V / 0(4)...20 mA  
 1 = Potentiometer  
 0 = Track control  
 1 = Coarse / fine control with 2 set points  
 Channel 1 inhibits channel 2  
 Channel 2 inhibits channel 1  
 0 = Solenoid output run on time 4 Sec..  
 1 = Solenoid output pre run time 1 Sec..  
 Run on time 4 Sec..  
 Run mode

### Only MTS 441

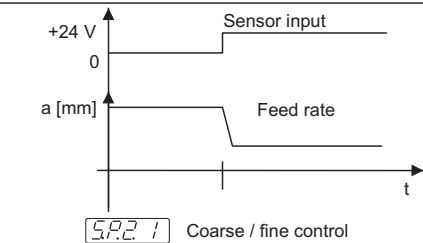
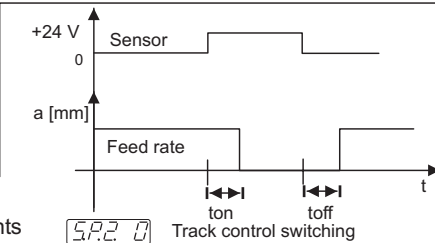
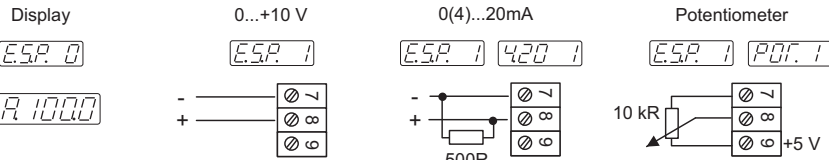

### Only MTS 442 Interlocking of channels

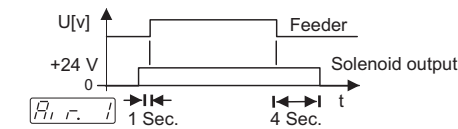
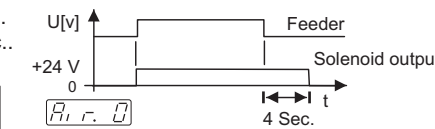

### Code 004 Feeder / Prefeeder

P     P  
 P     P  
 P     P  
 P     P  
 P     P  
 P     P  
 P     P  
 P     P

Channel 1  
 0 = Pulsed feed OFF  
 1 = Pulsed feed ON  
 Prefeed motor drive  
 0 = OFF  
 1 = ON  
 Channel 2  
 0 = Pulsed feed OFF  
 1 = Pulsed feed ON  
 Prefeed motor drive  
 0 = OFF  
 1 = ON  
 ON - Time  
 OFF - Time  
 Run mode

Output pulses with adjustable ON/OFF times  
 Operating mode for belt type prefeeder with a 1-phase motor drive  
 Output pulses with adjustable ON/OFF times  
 Operating mode for belt type prefeeder with a 1-phase motor drive  
 Adjustment of the ON/OFF pulse time  
 ON - Time  OFF - Time

**Code C 007 Track Control**

**Channel 1**

P   P

P   P Invert sensor function  
I = invert

P   P Switch On time delay

P   P Switch Off time delay

P  Run mode

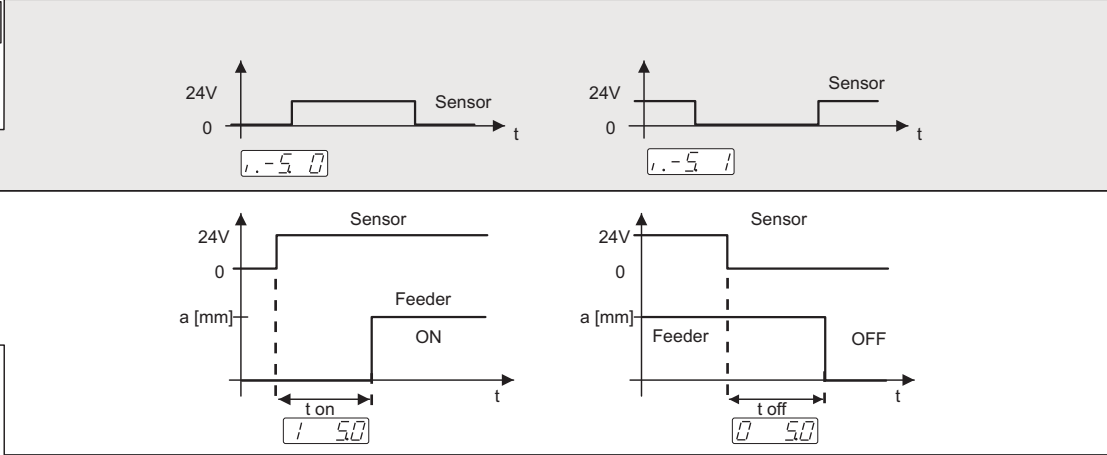

Invert sensor input

Sensor

Adjustment of the ON and OFF time delays

Time delays

**Code C 006 Track Control**

**Channel 2**

P   P

P   P Invert sensor function  
I = invert

P   P Switch On time delay

P   P Switch Off time delay

P  Run mode

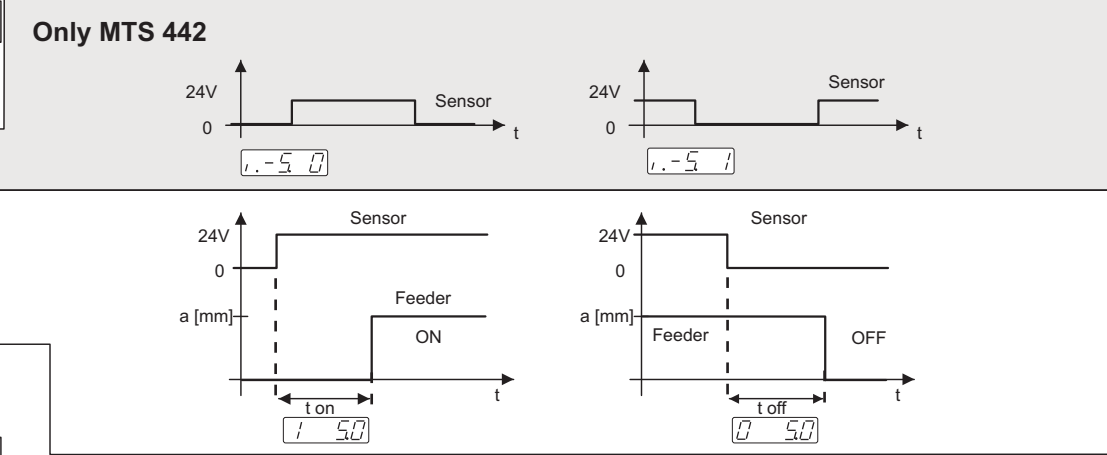

Invert sensor input

Sensors

Adjustment of the ON and OFF time delays

Time delays

**Code C 015 Sensor time out**

P   P

P   P Channel 1  
0 = Time-out not active  
I = Time-out active

P   P Channel 2 (only MTS 442)  
0 = Time-out not active  
I = Time-out active

P   P Time-out time [Sec.]

P  Run mode

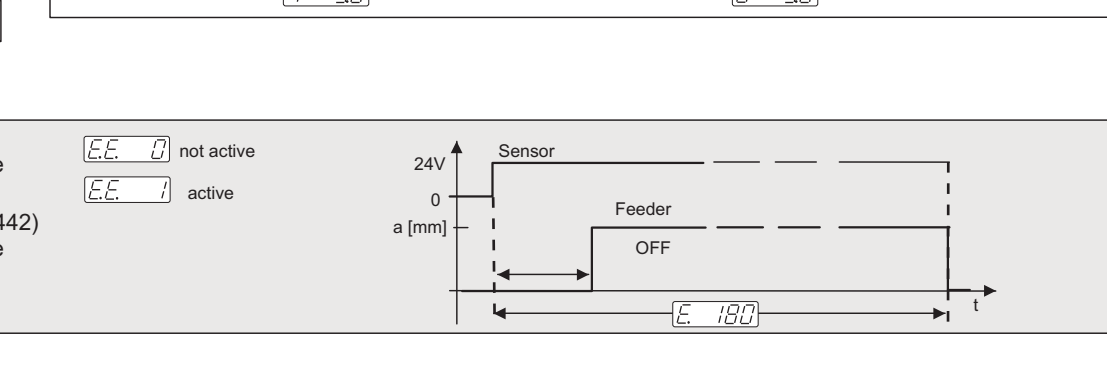

Sensor monitoring active.  
If no components are detected during the time out period the feeder switches off.

Sensor Monitoring

**Code C 020 Feeder Settings Channel 1**

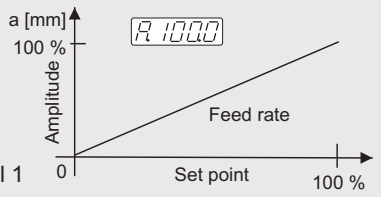

Symbol for Channel 1

Main set point

P   P

P   P

Feed rate channel 1

P   P

2. Set point (only if "S.P.2." = 1)

Coarse / fine control with two feed rates  
In Menu C 003 set "S.P.2." = 1!

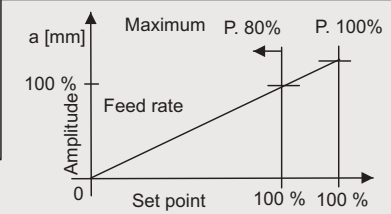
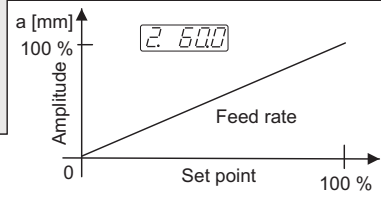

Set point for slow feed rate

Limiting the maximum feed rate.

The set point will still display 0....100% even though it is limited internally.

Set point

Maximum limit

P   P

Umax Channel 1

P   P

0 = Enable  
1 = Invert enable

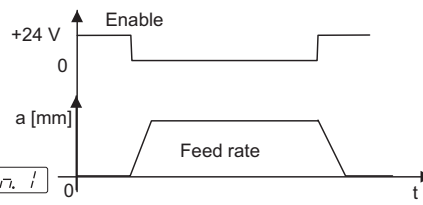
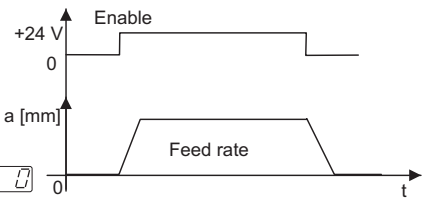

+24 V Signal or closed contacts will enable the output.

+24 V Signal or closed contacts will inhibit the output

Enable input

P   P

Vibrating frequency  
50 / 100 Hz (60 / 120 Hz)  
HA. = 0 = 100 Hz (120 Hz)  
HA. = 1 = 50 Hz (60 Hz)

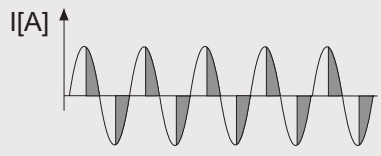

100 Hz (120 Hz)

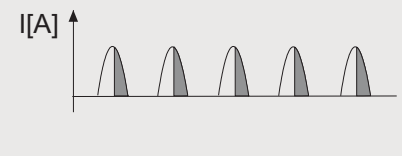

50 Hz (60 Hz)

The frequency setting depends upon the feeder type.  
**Important!**  
The wrong frequency setting can damage coils.

Vibrating frequency

P   P

Soft start channel 1

P   P

Soft stop channel 1

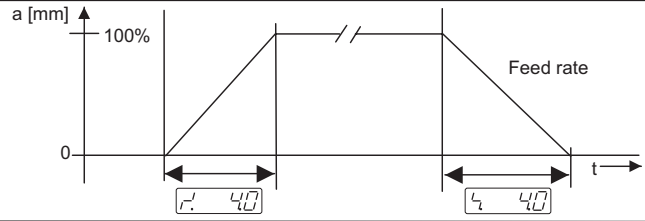

Time ramp for starting and stopping the feeder.

Soft start / stop

P  P

Return to run mode

Code C 021 Feeder Settings **Channel 2**

**Only MTS 442**

P   P

P   P

Feed rate channel 2

P   P

Umax Channel 2

P   P

0 = Enable  
1 = Invert enable

P   P

Vibrating frequency Channel 2  
50 / 100 Hz (60 / 120 Hz)  
HA. = 0 = 100 Hz (120 Hz)  
HA. = 1 = 50 Hz (60 Hz)

P   P

Soft start channel 2

P   P

Soft stop channel 2

P  Return to run mode

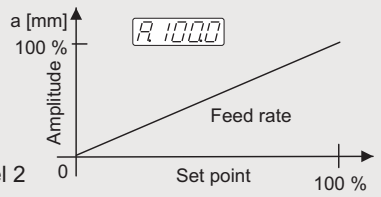

Symbol for Channel 2

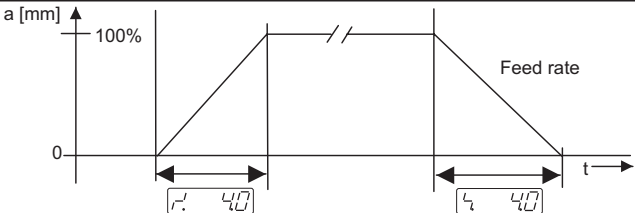
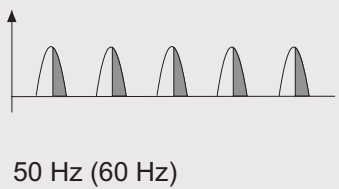
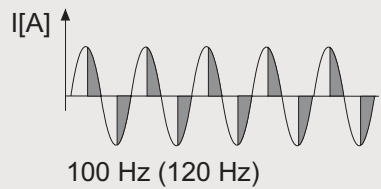
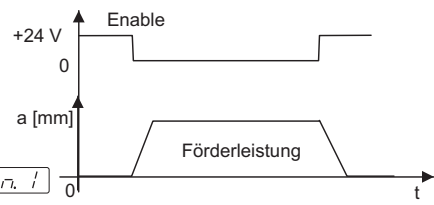
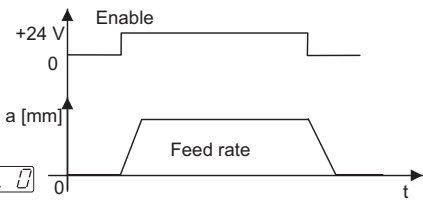
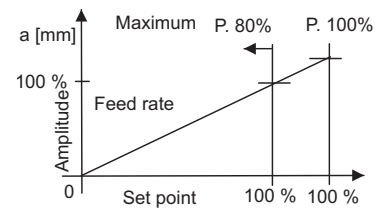

Feed rate set point

Set point

Limiting the maximum feed rate.  
The set point will still display 0...100% even though it is limited internally.

Maximum limit

+24 V Signal or closed contacts will enable the output.  
+24 V Signal or closed contacts will inhibit the output.

Enable input

The frequency setting depends upon the feeder type.  
**Important!**  
The wrong frequency setting can damage coils.

Vibrating frequency

Time ramp for starting and stopping the feeder

Soft start / stop

Code C 014 Sensor logic (MTS 440 and 442)

P C.000 [▲] [▼] C.014 P

P S.L.R. 0 [▲] [▼] S.L.R. 1 P Sensor 1 + 2 AND

P S.L.E. 0 [▲] [▼] S.L.E. 1 P Sensor 1 + 2 MIN-MAX

P 1000 Run mode

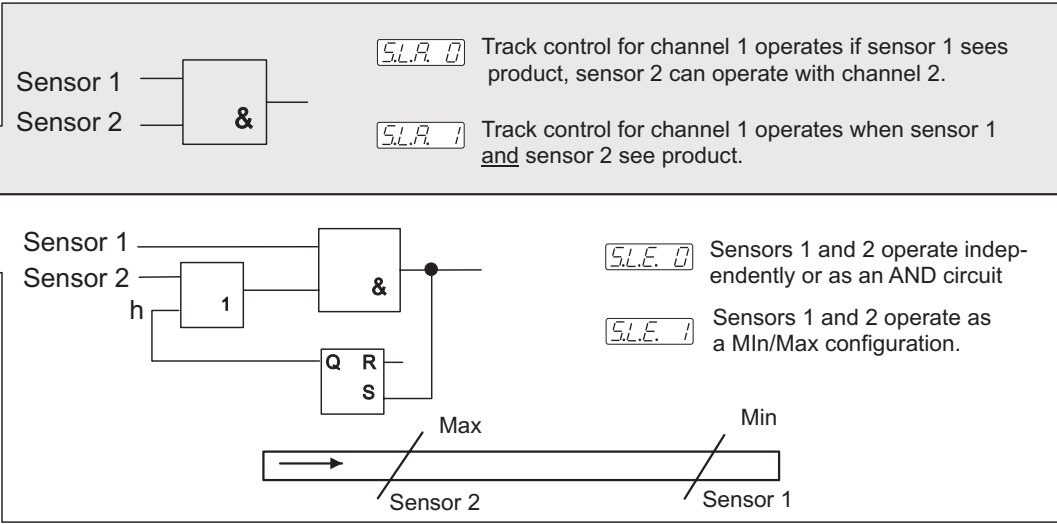

S.L.R. 0 Track control for channel 1 operates if sensor 1 sees product, sensor 2 can operate with channel 2.

S.L.R. 1 Track control for channel 1 operates when sensor 1 and sensor 2 see product.

S.L.E. 0 Sensors 1 and 2 operate independently or as an AND circuit

S.L.E. 1 Sensors 1 and 2 operate as a Min/Max configuration.

S2	S1		
Max.	Min		
h	Feeder		
0	0	0	1
0	1	1	1
1	1	1	0

Code 143 Save Current Parameters

P C.000 [▲] [▼] C.143 P

P PUSH [▲] [▼] SAFE P Save parameter settings

P 1000 Run mode

▲ All previously set parameters are saved

Save parameter settings

Code 210 Recall Parameters

P C.000 [▲] [▼] C.210 P

P FRC [▲] [▼] SAFE P Recall factory settings

P USPR [▲] [▼] SAFE P Recall user settings

P 1000 Run mode

▲ Recall factory settings

▲ Recall settings saved under C 143

Factory settings

Recall parameter settings previously stored under C143

Code 117 Inhibit Access

P C.000 [▲] [▼] C.117 P

P H.d.C. 0 [▲] [▼] H.d.C. 1 P I= Menu

P 1000 Run mode

H.d.C. 1 Parameter menus cannot be accessed, except the feed rate set point

H.d.C. 0 Parameter menus can be accessed

Hide programming menus

Sensor logic

Sensor logic

Service

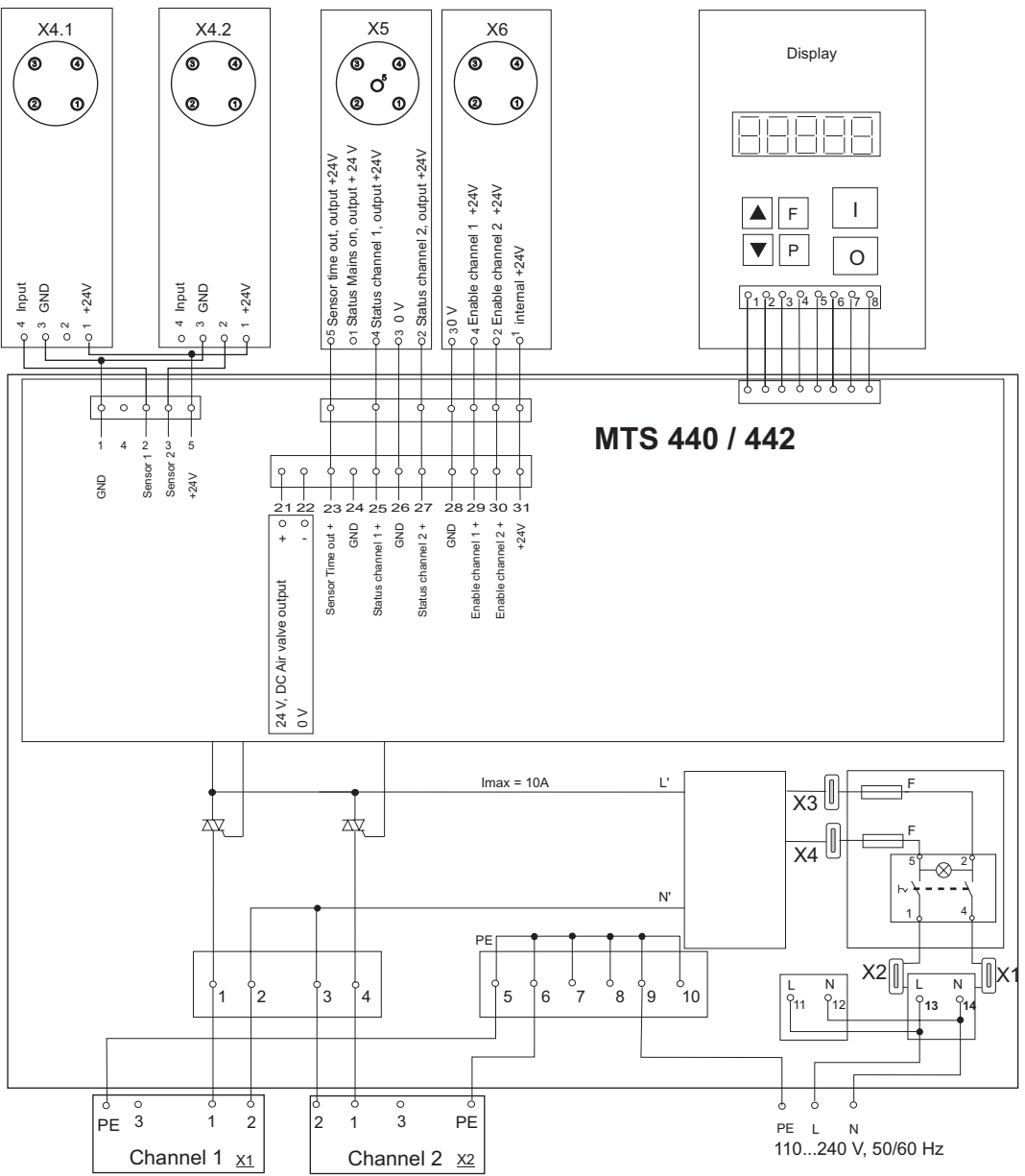
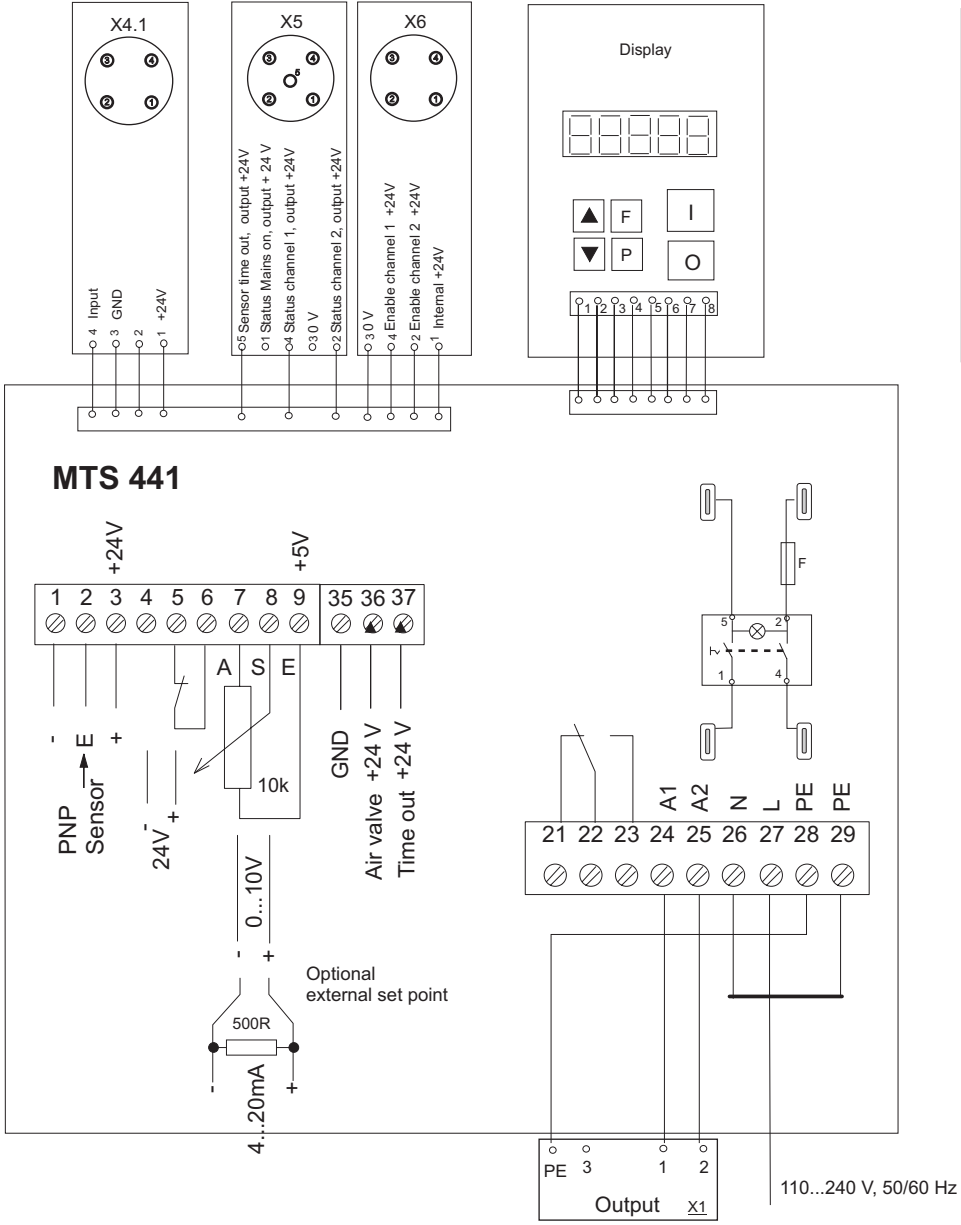

### MTS 441

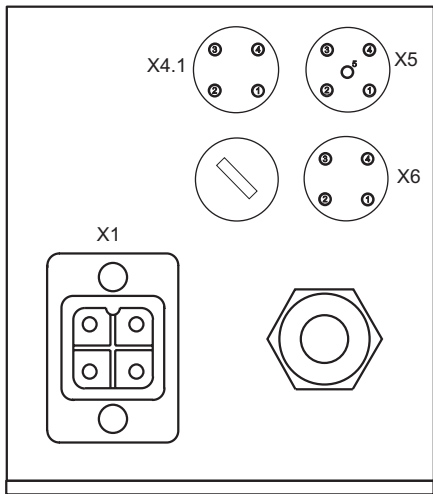

Sensor socket PNP Sensor ( X4.1 and X4.2 )

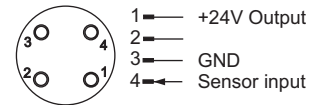

Status output ( X5 )

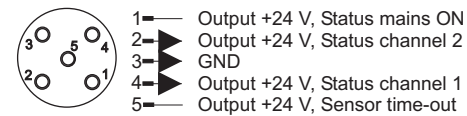

Enable input ( X6 )

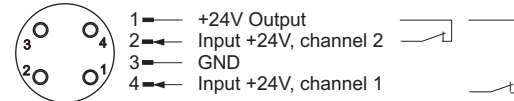

Output socket

Input connector or mains cable

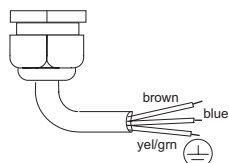
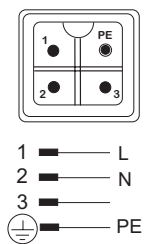
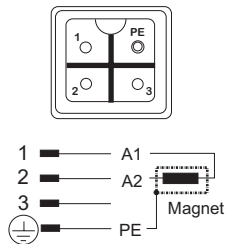

Air valve connection on internal terminals

### MTS 440 / MTS 442

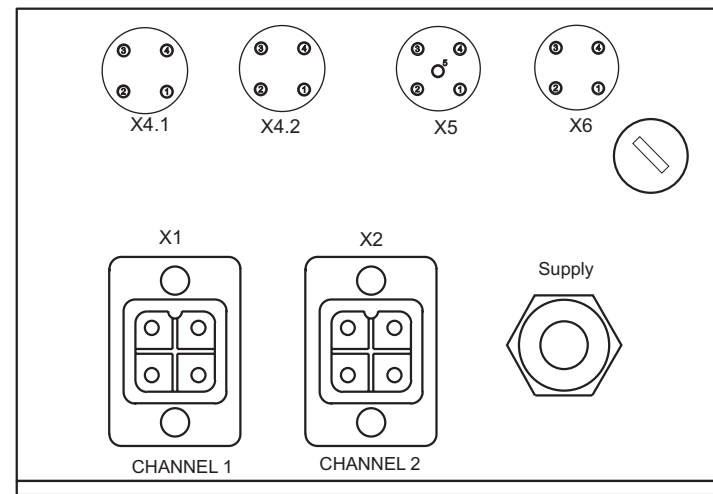

Output socket channel 1

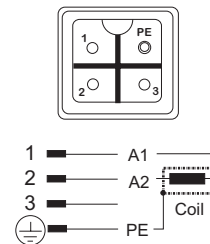

Output socket Channel 2

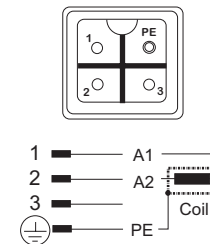

Input cable

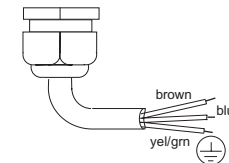

Input connector

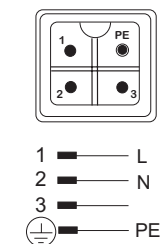

#### Ordering codes for plugs:

Output plug:		HA-4-M / 090212
Mains input:		HA-4-M-F / 090218
Track, enable:	Sensor plug 4 pin M12	RSV-M12-4 / 090131
Status signal:	Sensor plug 5pin M12	RSV-M12-5 / 090132

## Dimensions

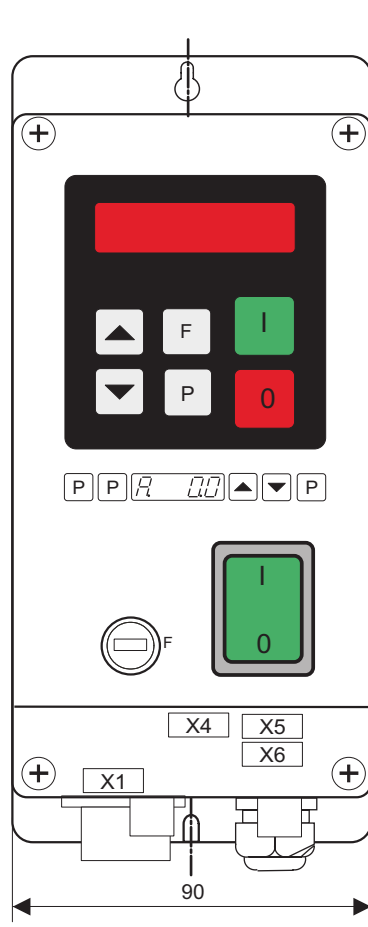

MTS 441

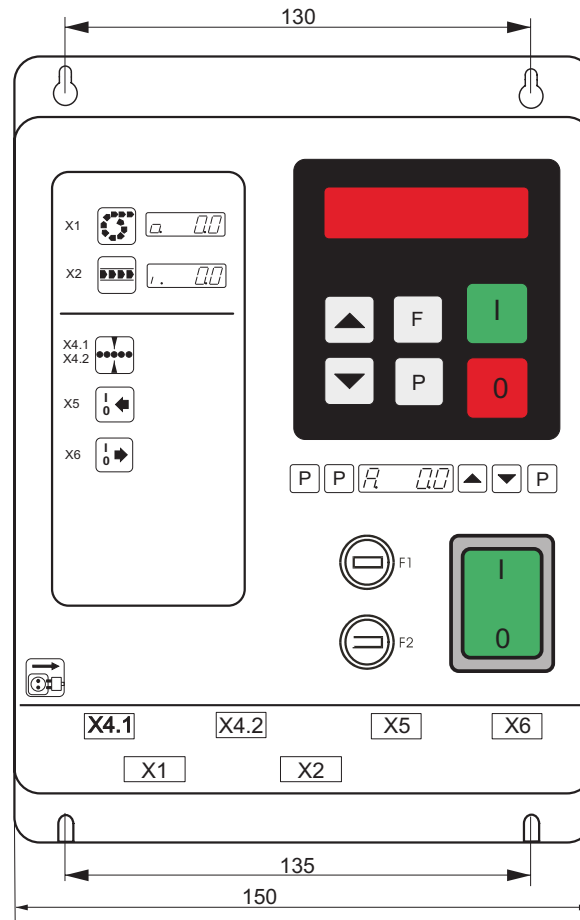

MTS 440 & 442

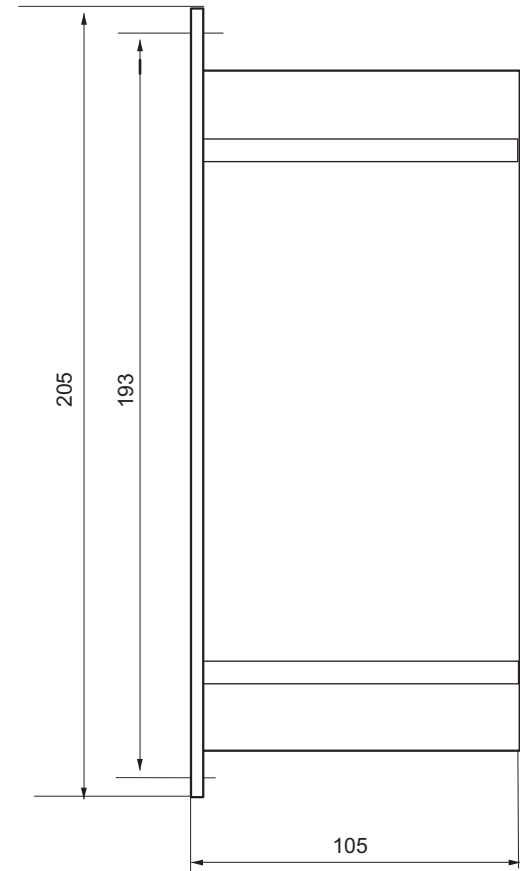

# Example

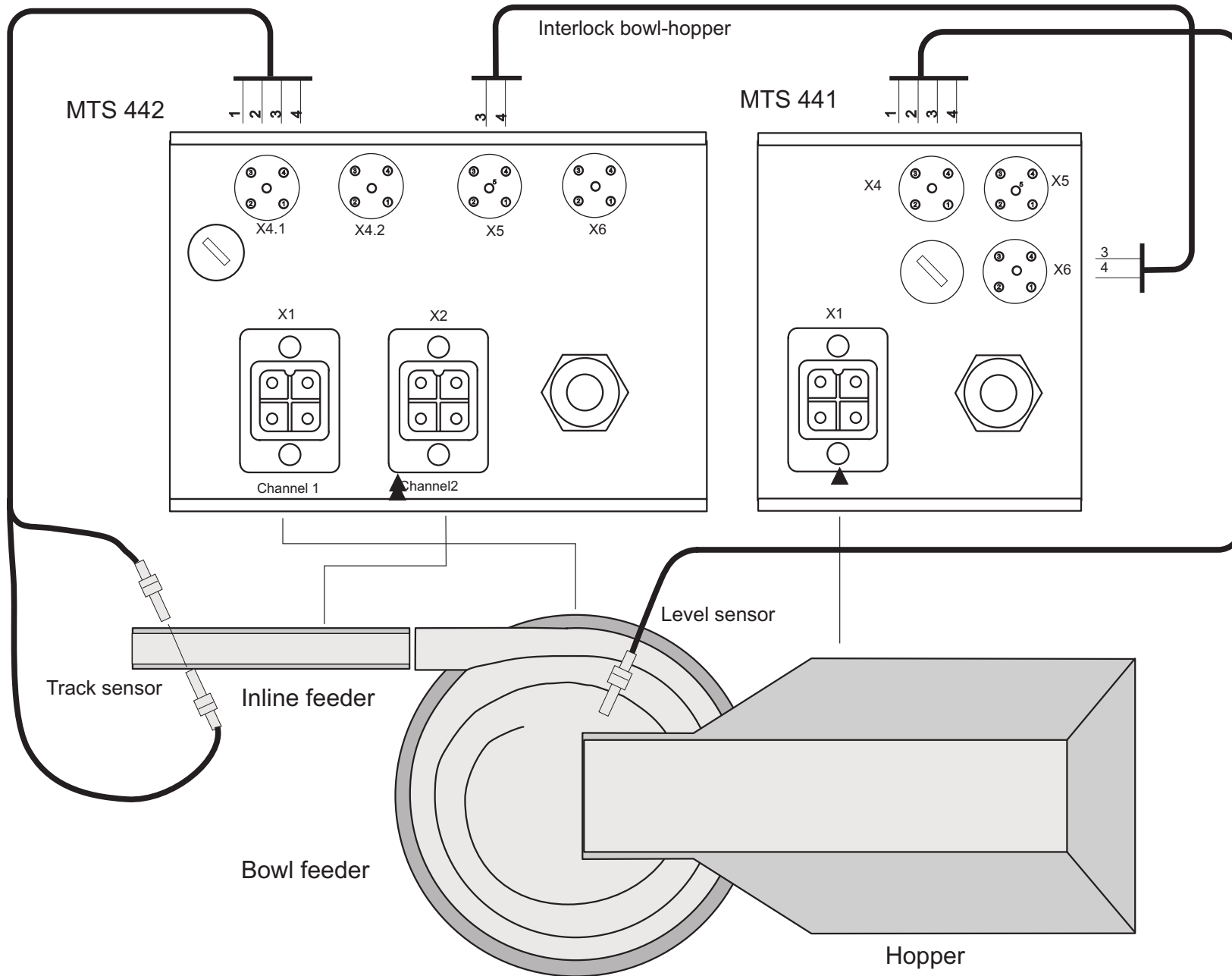

Example of a feed station comprising an inline and bowl feeder with a hopper.

Inline and bowl feeders are controlled with a REOVIB MTS 442 and the hopper with a REOVIB MTS 441.

The hopper is regulated from the bowl feeder through a 1:1 connection cable (status output from bowl feeder to hopper enable input)..