

# Automation Devices, Inc.

## MODEL 5 BASE UNIT ASSEMBLY DRAWING

Parts List		
Part Number	Quantity	Description
0501	1	Base Casting
0502	1	Top Casting
0503	*	Spring ( $\frac{1}{32}$ " thick)
0503A	optional	Spring ( $\frac{1}{16}$ " thick)
0504	optional	Spring ( $\frac{3}{32}$ " thick)
0505	optional	Spring ( $\frac{1}{8}$ " thick)
0506	**	Spring Spacer
0507	6	Spring Pad
0508	3	Foot
0511	optional	120 Volt Coil (Round)
0511A	1	120 Volt Coil (E-Frame)
0512	optional	240 Volt Coil (Round)
0512A	optional	240 Volt Coil (E-Frame)
0516A	optional	Armature
0520	1	#10-32 x $\frac{3}{8}$ " RHMS
0521	optional	#10-24 x $\frac{3}{4}$ " SHCS
0522	6	#10-24 x $\frac{5}{8}$ " SHCS
0535	1	Rubber Adjusting Ring
0536	1	$\frac{3}{8}$ "-24 x $1\frac{1}{4}$ " SHCS
0537	2	$\frac{3}{8}$ " Washer
0834	1	Coil Adjustment Washer
0918	optional	24 Volt Coil (E-Frame)
8626	1	#10-32 x $\frac{3}{8}$ " Gnd Screw
C083	1	$\frac{3}{16}$ x 1" Roll Pin

\* Quantity required is either 6, 9, or 12.  
Other optional springs are available.  
When ordering replacement springs,  
specify the spring thickness.

\*\* Quantity required is determined by  
doubling the number of springs.

When ordering replacement parts, specify  
the *serial number* on the unit  
nameplate.

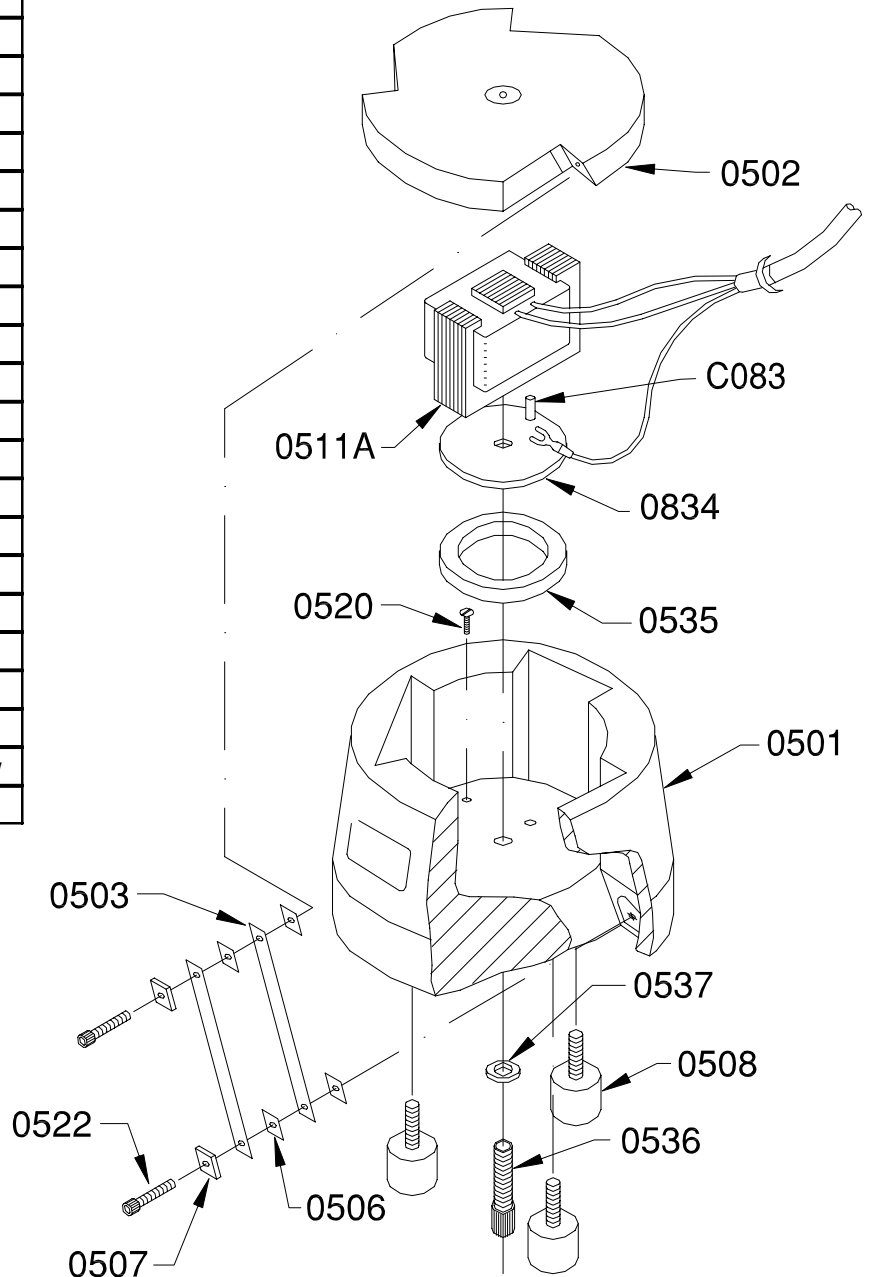

AE02.01

### Automation Devices, Inc.

7050 West Ridge Road  
Fairview, PA 16415-2099

Phone: 814-474-5561

FAX: 814-474-2131 or 800-235-9382

Web Site: [www.autodev.com](http://www.autodev.com) E-mail: [info@autodev.com](mailto:info@autodev.com)